

VARI***LITE**

VARI***LITE**

VL10 BeamWash



USER'S MANUAL

All other brand or product names which may be mentioned in this manual are trademarks or registered trademarks of their respective companies or organizations.

The information furnished in this manual is for informational use only and is subject to change without notice. Please check <http://www.philips.com/entertainmentlighting> for latest version. Vari-Lite assumes no responsibility or liability for any errors or inaccuracies that may appear in this manual. All information and graphics are property of Vari-Lite, 10911 Petal Street Dallas, Texas 75238 USA.

Version as of: **15 October 2018 VL10 BeamWash**
Part number: **02.1810.0002**

VL10 BeamWash User's Manual
©2013 Vari-Lite. All Rights Reserved.

How To Obtain Warranty Service

A copy of the Vari-Lite Limited Warranty was included in the shipping package for this VARI***LITE** product.

To obtain warranty service, please contact customer service at 1-877-VARI-LITE (1-877-827-4548), +1-214-647-7880, or entertainment.service@signify.com and request a Return Material Authorization (RMA) for warranty service. You will need to provide the model and serial number of the item being returned, a description of the problem or failure and the name of the registered user or organization. If available, you should have your sales invoice to establish the date of sale as the beginning of the warranty period.

Once you obtain the RMA, pack the unit in a secure shipping container or in its original packing box. Be sure to clearly indicate the RMA number on all packing lists, correspondence, and shipping labels. If available, please include a copy of your invoice (as proof of purchase) in the shipping container. With the RMA number written legibly on or near the shipping address label, return the unit, freight prepaid, to:

Vari-Lite
Attention: Warranty Service (RMA# _____)
10911 Petal Street
Dallas Dallas, Texas 75238 USA
Attention: Warranty Service

As stated in the warranty, it is required that the shipment be insured and FOB our service center.



IMPORTANT! When returning products to Vari-Lite for repairs (warranty or out-of-warranty) from a country other than the USA, “**Philips Lighting Controls Division**”, must appear in the address block as the Importer of Record (IOR) on all shipping documentation, Commercial Invoices, etc. This must be done in order to clear customs in a timely manner and prevent returns.

Compliance Notices

FCC This equipment has been tested and found to comply with the limits for a Class A digital device pursuant to Part 15 of FCC Rules. These limits are designed to provide reasonable protection against harmful interference when this equipment is operated in a commercial environment. This equipment generates, uses, and can radiate radio frequency energy and, if not installed and used in accordance with Vari-Lite system, service, and safety guidelines, may cause harmful interference to radio communications. Operation of this equipment in a residential area is likely to cause harmful interference, in which case the user will be required to correct the interference at his/her own expense.

CE Declaration of Conformity

We declare, under our sole responsibility, that this product complies with the relevant clauses of the following standards and harmonized documents:

Safety

EN 60598-1:2015; EN 60598-2-17:1989+A2:1991;EN 62493:2015;EN 62031:2008+A1:2013+A2:2015;EN 62471:2008;Low Voltage Directive 2014/35/EU

EMC

EN 55015:2013
EN 61000-3-2:2014
EN 61000-3-3:2013
EN 61547:2009
EMC Directive 2014/30/EU
Same as Legal Entity

RoHS

EN 62321:2012

We certify that the product conforms to the protection requirements of council directives: Low Voltage Directive 2014/35/EU, 2014/30/EU (EMC), and Restriction of the use of certain Hazardous Substances in electrical and electronic equipment Directive (RoHS), 2015/863. Equipment referred to in this declaration of conformity was first manufactured in 2017 in compliance with these standards.

Safety Notices

It is extremely important to read ALL safety information and instructions provided in this manual and any accompanying documentation before installing and operating the products described herein. Heed all cautions and warnings during installation and use of this product.

Safety symbols used throughout this manual are as follows:



CAUTION advising of potential damage to product.



WARNING advising of potential injury or death to persons.

GENERAL INFORMATION PERTAINING TO PROTECTION AGAINST ELECTRICAL SHOCK, FIRE, EXPOSURE TO EXCESSIVE UV RADIATION, AND INJURY TO PERSONS CAN BE FOUND BELOW.

WARNING:

INSTRUCTIONS FOR CONTINUED PROTECTION AGAINST FIRE

- 1 Luminaires may be mounted on any type of surface as long as mounting instructions are followed. See instructions detailed in this manual.
- 2 Note distance requirement from combustible materials or illuminated objects for VARI*LITE luminaires.

WARNING:

INSTRUCTIONS FOR CONTINUED PROTECTION AGAINST ELECTRICAL SHOCK

- 1 VARI*LITE luminaires are designed for dry locations only. Exposure to rain or moisture may damage luminaire.
- 2 Disconnect power before servicing any VARI*LITE equipment.
- 3 Servicing to be performed by qualified personnel only.

WARNING:

INSTRUCTIONS FOR CONTINUED PROTECTION AGAINST EXCESSIVE EXPOSURE TO UV RADIATION

1. Many VARI***LITE** luminaires use a lamp that produces UV radiation. **DO NOT** look directly at lamp.
2. It is hazardous to operate luminaires without lens or shield. Shields, lenses, or ultraviolet screens shall be changed if they have become visibly damaged to such an extent that their effectiveness is impaired. For example, by cracks or deep scratches.

WARNING: INSTRUCTIONS FOR PROTECTION AGAINST INJURY TO PERSONS

1. Exterior surfaces of the luminaire will be hot during operation. Use appropriate safety equipment (gloves, eye protection, etc.) when handling and adjusting hot equipment and components.
2. Luminaires will have a hot lamp when operating. Disconnect power and allow lamp to cool before replacing.
3. Lamp emit ultraviolet radiation which can cause serious skin burn and eye inflammation. Additionally, lamp operate under high pressure at very high temperatures. Should the lamp break, there can exist a danger of personal injury and/or fire from broken lamp particles being discharged.
4. Wear eye protection when relamping.
5. Appropriate safety equipment (gloves, eye protection) should be used when handling damaged lamp.
6. If lamp is touched with bare hands, clean lamp with denatured alcohol and wipe with lint-free cloth before installing or powering up the luminaire.
7. The lamp shall be changed if it has become damaged or thermally deformed.

WARNING: RF INTERFERENCE

1. This is a Class A product. In a domestic environment this product may cause radio interference, in which case, the user may be required to take adequate measures.

LAMP CHARACTERISTIC CONSIDERATIONS

1. Lamp require a period of time to relight after a power interruption or a severe voltage dip. In some cases, lamp will automatically relight after it has cooled depending on Power-Up State configuration setting.
2. Burning position is Universal.

Sicherheitshinweise

Es ist äußerst wichtig, ALLE Sicherheitsinformationen und -hinweise in diesem Handbuch und dem beiliegenden Informationsmaterial zu lesen, bevor Sie die hierin beschriebenen Produkte installieren bzw. bedienen. Halten Sie bei der Installation und dem Einsatz dieses Produkts alle Warnhinweise und Vorsichtsmaßnahmen ein.

Folgende Sicherheitssymbole werden in diesem Handbuch verwendet:



VORSICHT - weist auf möglichen Produktschaden hin.



WARNUNG - weist auf mögliche Körperverletzung und Lebensbedrohung hin.

NACHSTEHEND FINDEN SIE ALLGEMEINE HINWEISE ÜBER SICHERHEITSVORKEHRUNGEN GEGEN ELEKTROSCHOCK, FEUER, ÜBERHÖHTE UVSTRAHLUNG UND KÖRPERVERLETZUNGEN.

WARNUNG: HINWEISE ZUM FEUERSCHUTZ

1. VARI***LITE** -Scheinwerfer sind ausschließlich für den Einsatz mit bestimmten Lampentyps. Achten Sie auf den Lampentyp (MSD Platinum 25R 550W Lamp), bevor Sie die jeweiligen Lampen ersetzen. Die Installation eines anderen Lampentyps kann gefährlich sein.
2. Scheinwerfer können auf jeder beliebigen Oberfläche montiert werden, solange Sie die Montageanweisungen befolgen. Detaillierte Hinweise finden Sie in diesem Handbuch.
3. Beachten Sie die Einhaltung des erforderlichen Sicherheitsabstandes der VARI***LITE** -Scheinwerfer von brennbarem Material oder beleuchteten Objekten.

WARNUNG: HINWEISE ZUM SCHUTZ GEGEN ELEKTROSCHOCK

1. VARI***LITE** -Scheinwerfer eignen sich ausschließlich für trockene Standorte. Regen oder Feuchtigkeit können die Scheinwerfer beschädigen.
2. Unterbrechen Sie die Stromzufuhr, bevor Sie mit der Arbeit an VARI***LITE** -Geräten beginnen.
3. Die Geräte sollten nur von qualifiziertem Personal gewartet werden.

WARNING:

HINWEISE ZUM SCHUTZ GEGEN ÜBERHÖHTE UV-STRAHLUNG

1. Viele VARI*LITE -Scheinwerfer verwenden die Lampentyp, der UV-Strahlen abgibt. SCHAUEN SIE NICHT direkt in die Lampe.
2. Es ist gefährlich, Leuchten ohne Linsen oder Blenden zu bedienen. Blenden, Linsen oder Ultraviolettsschirme müssen ausgetauscht werden, sofern deren Schutzwirkung durch sichtbare Beschädigung (z. B. Sprünge oder Schrammen) eingeschränkt ist.

WARNING:

HINWEISE ZUM SCHUTZ GEGEN KÖRPERVERLETZUNGEN

1. Bei Betrieb sind die Außenflächen der Scheinwerfer heiß. Verwenden Sie bei der Bedienung von aufgeheizter Apparatur die jeweils geeignete Sicherheitsausrüstung (Handschuhe, Augenschutz etc.).
2. Bei Betrieb der Scheinwerfer ist die Lampe heiß. Unterbrechen Sie die Stromzufuhr und lassen Sie die Lampe abkühlen, wenn Sie diese austauschen.
3. Bogenlampen senden ultraviolette Strahlen aus, die Hautverbrennungen und Augentzündungen verursachen können. Der Betrieb von Bogenlampen erfolgt unter Hochdruck und bei hohen Temperaturen. Sollte die Lampe zerbrechen, besteht die Gefahr von Körperverletzung bzw. von Feuer, das von Lampenteilen ausgelöst werden kann.
4. Tragen Sie beim Austausch der Lampen einen Augenschutz.
5. Die geeignete Sicherheitsausrüstung (Handschuhe, Augenschutz) sollte beim Umgang mit beschädigten Lampen verwendet werden.
6. Wenn die Lampe mit bloßen Händen berührt wird, reinigen Sie sie mit denaturiertem Alkohol und einem flusenfreien Tuch, bevor Sie die Scheinwerfer installieren oder in Betrieb nehmen.
7. Wenn die Lampe beschädigt oder durch Hitzeeinwirkung deformiert ist, muß diese ausgetauscht werden.

WARNING:

HF-INTERFERENZ

1. Es handelt sich um ein Produkt der Klasse A. In einer Wohnumgebung kann das Produkt Hochfrequenzstörungen verursachen. In diesem Fall müssen eventuell geeignete Maßnahmen getroffen werden.

BESONDERHEITEN VON BOGENLAMPEN

1. Bogenlampen benötigen eine gewisse Zeitdauer, um nach einem Stromausfall oder einem Spannungsgefälle wieder aufzuleuchten. In einigen Fällen wird die Lampe nach Abkühlung automatisch wieder aufleuchten, je nach der Systemkonfigurationseinstellung des Lampeneinschaltungsstatus.
2. Die Brennposition ist Universal.

Notes de sécurité

Avant de procéder à l'installation des produits décrits dans ce guide et de les mettre en marche, il est extrêmement important de lire TOUS les renseignements et TOUTES les directives de sécurité contenues dans ce guide ainsi que toute documentation jointe. Tenir compte de tous les avertissements et suivre toutes les précautions pendant l'installation et l'utilisation de cet appareil.

Les symboles de sécurité utilisés dans ce guide sont les suivants :



ATTENTION Ce symbole annonce que l'appareil risque d'être endommagé.



AVERTISSEMENT Ce symbole annonce qu'il y a risque d'accident grave ou même fatal.

CETTE SECTION CONTIENT DES INFORMATIONS GÉNÉRALES POUR SE PROTÉGER CONTRE LES DÉCHARGES ÉLECTRIQUES , LES INCENDIES, L'EXPOSITION EXCESSIVE AUX RAYONS UV ET TOUT AUTRE ACCIDENT POUVANT ENTRAÎNER DES BLESSURES.

AVERTISSEMENT:

DIRECTIVES POUR SE PROTÉGER CONTRE LES INCENDIES

1. Les luminaires VARI***LITE** ont été conçus pour être utilisés uniquement avec certaines type de lampes. Vérifier le type de lampe (MSD Platinum 25R 550W Lampe) avant de remplacer les lampes. L'installation d'un autre type de lampe peut poser un danger.
2. Les luminaires peuvent être fixés sur tout type de surface tant que les directives de montage sont respectées. Voir les explications détaillées dans ce guide.
3. Vérifier la distance à respecter entre les matériaux combustibles ou les objets illuminés et les luminaires VARI***LITE** .

AVERTISSEMENT:

DIRECTIVES POUR SE PROTÉGER CONTRE LES DÉCHARGES ÉLECTRIQUES

1. Les luminaires VARI***LITE** sont conçus pour une utilisation au sec uniquement. Une exposition à la pluie et à l'humidité risque d'endommager le luminaire.
2. Débrancher l'appareil avant de procéder à la révision de tout matériel VARI***LITE** .
3. Les révisions doivent être effectuées uniquement par des personnes qualifiées.

AVERTISSEMENT:

DIRECTIVES POUR SE PROTÉGER CONTRE UNE EXPOSITION EXCESSIVE AUX RAYONS UV

1. Plusieurs luminaires VARI*LITE utilisent une lampe qui produit des rayons UV. NE PAS fixer son regard sur la lampe.
2. L'utilisation des luminaires sans lentille ou blindage pose des risques. Tous blindages, lentilles ou écrans ultraviolet visiblement endommagés au point que leur efficacité en est affectée doivent être remplacés, par exemple s'il y a des fissures ou de profondes rayures.

AVERTISSEMENT:

DIRECTIVES POUR SE PROTÉGER CONTRE LES ACCIDENTS POUVANT ENTRAÎNER DES BLESSURES

1. Les surfaces externes du luminaire deviennent brûlantes quand l'appareil est en marche. Pour manœuvrer ou ajuster des appareils brûlants et leurs composants, se protéger suffisamment (gants, protection pour les yeux, etc.).
2. La lampe du luminaire est brûlante lorsqu'il est en marche. Débrancher le courant et attendre que la lampe ait refroidi avant de la remplacer.
3. Les lampes à émettent des rayons ultraviolets pouvant causer de graves brûlures sur la peau et une inflammation des yeux. De plus, les lampes à fonctionnent sous haute tension à de très hautes températures. Si la lampe se casse, les particules de la lampe cassée peuvent causer blessures et/ou incendie en s'éparpillant.
4. Se protéger les yeux pour remplacer la lampe.
5. Utiliser des appareils de protection appropriés (gants, protection des yeux) pour manier des lampes endommagées.
6. Si la lampe a été touchée avec des mains nues, la nettoyer avec de l'alcool dénaturé et l'essuyer avec un chiffon non-pelucheux avant d'installer ou de brancher le luminaire.
7. Si la lampe a été endommagée ou a reçu une déformation thermique, elle doit être remplacée.

AVERTISSEMENT:

INTERFÉRENCE

RF

1. Cet appareil est de Classe A. Dans un environnement domestique, cet appareil peut causer des interférences radio, et si c'est le cas, l'utilisateur peut avoir à prendre des mesures adéquates.

CONSIDÉRATIONS DES CARACTÉRISTIQUES DE LAMPES À

1. Après une interruption de courant ou une baisse importante de voltage, les lampes à mettent du temps avant de se rallumer. Dans certains cas, la lampe se rallumera automatiquement après s'être refroidie. Cela dépend de la manière dont le système est réglé pour le statut de mise en marche de la lampe.
2. La position Brûler est Universelle.

Aviso sobre Seguridad

Es muy importante leer TODA la información e instrucciones sobre seguridad que se indica en este manual así como en los documentos adjuntos antes de instalar y operar los productos descritos. Se debe prestar atención a todos los avisos y advertencias durante la instalación y uso de este producto.

Los símbolos de seguridad usados en este manual son los siguientes:



CUIDADO, indica posibles daños al producto.



ADVERTENCIA, indica posibles lesiones o muerte a las personas.

LA INFORMACIÓN GENERAL RELACIONADA A LA PROTECCIÓN CONTRAGOLPES DE CORRIENTE ELÉCTRICA, INCENDIO, EXPOSICIÓN EXCESIVA A RADIACIÓN ULTRA VIOLETA Y LESIONES A LAS PERSONAS SE PUEDE ENCONTRAR SEGUIDAMENTE:

ADVERTENCIA:

INSTRUCCIONES PARA PROTECCIÓN CONTINUA CONTRA INCENDIO

1. Las luminarias VARI *LITE han sido diseñadas para ser usadas solamente con algunas lámparas. Tome nota del tipo de lámpara (MSD Platinum 25R 550W Lamp) antes de reemplazarla. Instalación de otro tipo de lámpara puede ser peligroso.
2. Las luminarias se pueden instalar en cualquier tipo de superficie siempre que se sigan las instrucciones de instalación. Vea las instrucciones detalladas en este manual.
3. Tome nota de los requerimientos de distancia de materiales combustibles u objetos iluminados para las luminarias VARI *LITE .

ADVERTENCIA:

INSTRUCCIONES PARA PROTECCIÓN CONTINUA CONTRA CHOQUE ELÉCTRICO

1. Las luminarias VARI *LITE están diseñadas solamente para lugares secos. La exposición a la lluvia o humedad pueden dañar la luminaria.
2. Desconecte la energía antes de dar servicio a cualquier equipo de VARI *LITE .
3. El servicio debe ser realizado solamente por personal calificado.

ADVERTENCIA:

INSTRUCCIONES PARA PROTECCIÓN CONTINUA CONTRA LA EXPOSICIÓN EXCESIVA DE RADIACIÓN ULTRA VIOLETA

1. Muchas luminarias VARI*LITE usan un tipo de lámpara que produce radiación UV. NO mire directamente a la lámpara.
2. Es peligroso operar luminarias sin lentes o protectores. Debe cambiar los protectores, lentes o pantallas ultravioletas si se aprecia que han sido dañadas, y que su efectividad pudiera estar deteriorada. Por ejemplo, si tuvieran rajaduras o raspaduras profundas.

ADVERTENCIA:

INSTRUCCIONES PARA PROTECCIÓN CONTRA LESIONES DE PERSONAS

1. Las superficies exteriores de las luminarias están calientes durante su operación. Use un equipo de seguridad apropiado (guantes, protección para los ojos, etc.) cuando haga ajustes en el equipo y componentes que están calientes.
2. Cuando las luminarias están en operación la lámpara estará muy caliente. Desconecte la energía y deje que la lámpara se enfríe antes de reemplazarla.
3. Las lámparas de arco emiten radiaciones ultravioletas que pueden ocasionar serias quemaduras a la piel e inflamación a los ojos. Además, las lámparas de arco operan a alta presión y muy alta temperatura. Si la lámpara se rompe, puede existir el peligro de lesiones al personal o un incendio ocasionado por las partículas de la lámpara rota que se caen.
4. Use protección para los ojos cuando vuelve a colocar una lámpara nueva.
5. Use un equipo de seguridad apropiado (guantes, protección para los ojos, etc.) cuando trabaje con lámparas dañadas.
6. Si toca la lámpara con las manos, limpie la lámpara con alcohol desnaturalizado y con tela sin pelusas antes de instalar o volver a conectar la luminaria.
7. Cambie la lámpara si está dañada o deformada termicamente.

ADVERTENCIA:

INTERFERENCIA

RF

1. Este es un producto de Clase A. En el ambiente de la casa este producto puede ocasionar radiointerferencia, en cuyo caso, el usuario debe tomar las medidas adecuadas.

CONSIDERACIONES SOBRE LAS CARACTERÍSTICAS DE LA LÁMPARA DE ARCO

1. Las lámparas de arco requieren un período de tiempo para volver a iluminarse después de una interrupción de energía o de una severa caída de voltaje. En algunos casos, la lámpara se volverá a iluminar en forma automática después que se ha enfriado dependiendo de la configuración del sistema de energía de la lámpara.
2. La posición de encendido es universal.

Introduction

About This Manual.....1
 Additional Documentation.....1
 Text Conventions2
 Customer Service2

Chapter 1. Description

Features

VL10 BeamWash Standard Features4

Components

Included Items5
 Overview6

Chapter 2. Installation

Special Warnings

Exceptional Safety Information for the VL10 BeamWash.....9

Power and Data Cabling Requirement

Power10
 DMX Termination Connector11

Installation Procedures

Hanging the Luminaire12
 Floor Mounting the Luminaire14

Powering Up

Power Up and Configuration Procedure15

Addressing

Program Starting Address16
 Program Starting Address Without Calibrating Luminaire16

Chapter 3. Operation

VL10 BeamWash DMX Channels

VL10 BeamWash Channel Mapping18
 VL10 BeamWash Control Channel Functions28

VL10 BeamWash DMX Mapping

VL10 BeamWash Color Control30
 Color Mixing.....30
 Color Wheel30
 Color Wheels DMX Map31
 VL10 BeamWash Beam Control32
 Strobe.....32
 VL10 BeamWash Gobo/Effects Control33
 Overview of Gobos used in VL10 BeamWash33
 Gobo Use and Positioning.....33
 Fixed Aperture Wheel (Gobo Wheel 1)34
 Gobo Wheel 235
 VLFX Wheels.....36
 Index and Rotation37

VL10 BeamWash Timing
 VL10 BeamWash Timing Channel Information..... 39

Updating Software
 Software From Luminaire to Luminaire 48

Chapter 4. Menu System

Menu Operation
 What Is the Menu System? 52
 Controls Operation 52
 Default State..... 53

Menu Functions
 VL10 BeamWash Menu System Function Chart..... 54

Self-Tests
 Running Parameter Tests..... 56

Appendix A. Luminaire Care and Routine Maintenance

Equipment Handling
 Locations/Use 59
 Lamp..... 59
 Servicing 59
 Heat..... 59
 Lamp..... 59
 Solid State Electronics 60
 Electrostatic Discharge (ESD) 60
 Printed Circuit Boards (PCBs)..... 60

Troubleshooting
 Error Messages 61

Routine Maintenance
 Replacement..... 62
 Gobo Replacement - Gobo Wheels 63
 Cleaning Optics, Filters and Gobos..... 66

Appendix B. Technical Specifications
 VL10 BeamWash 67

Introduction

About This Manual

This manual provides necessary information regarding safety, installation, operation and routine maintenance for VARI*LITE VL10 BeamWash. Familiarizing yourself with this information will help you to get the most out of your luminaire.



WARNING: It is important to read ALL accompanying safety and installation instructions to avoid damage to the product and potential injury to yourself or others.

This manual covers the following models:

Model	Part Number	Source
VL10 BeamWash	20.1810.0001	MSD Platinum 25R 550W Lamp

Additional Documentation

A service manual, only for Authorized VARI*LITE Service Centers and technicians, of the VL10 BeamWash is available in electronic (PDF) format:

- Luminaire Service Manual
- Testing, Troubleshooting, Component Replacement and Illustrated Parts Breakdown.















Note: Performing maintenance procedures may void the product warranty. Refer to the Vari-Lite Limited Warranty card included in the product shipping package for more information.

For more information on installing DMX512 control systems, the following publication is available for purchase from the United States Institute for Theatre Technology (USITT), "Recommended Practice for DMX512: A Guide for Users and Installers, 2nd edition" (ISBN: 9780955703522). USITT Contact Information:

USITT Inc.
 315 South Crouse Avenue Suite 200
 Syracuse, NY 13210
 Tel: 800-938-7488 or +1-315-463-6463
 Fax: 866-398-7488 or +1-315-463-6525
www.usitt.org

Text Conventions

The following styles and meanings are used throughout this manual:

Style	Meaning
[Button]	Front panel button. Example: Press  / 
   	Press either     arrow button at Menu Display.
MENU	LCD Menu Display read-out. Example: Press     arrows until DMX appears.

Customer Service

Our Goal

At Vari-Lite, we are committed to providing you the highest quality in customer service. Our comprehensive resources are available to help your business succeed and ensure you get the full benefit of being a Vari-Lite customer. Whether your needs are telephone troubleshooting assistance, product training or technical service, our full-time staff of experienced professionals is on-hand to provide support.

How to Reach Us

For assistance in your area, call the dealer from which your product was purchased.

or

Contact an Authorized VARI*LITE Service Center.

or

Contact the Vari-Lite Customer Service Department, 9am -6pm CST Monday through Friday, at the following:

phone: 1-877-VARI-LITE (1-877-827-4548) or +1-214-647-7880

email: entertainment.service@signify.com

Additional Resources

For additional resources and documentation, please visit our website at <http://www.philips.com/entertainmentlighting> and follow the Support link.

CHAPTER 1.

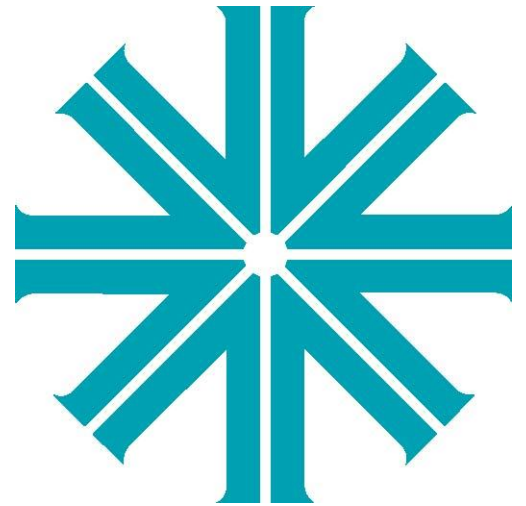

Description

This chapter contains descriptions of luminaire features and components, along with a list of accessories which are available.

- [Features](#)
- [Components](#)

Features



VL10 BeamWash Standard Features

- Exclusive new Philips 25R Platinum 550W lamp
- The brightest fixture in its class 28,000 lumen of output
- Wide zoom range – 2.2° to 48°
- Narrowest beam reduction 0.7°
- Large impact stage presence from a 180mm front lens, a look only usually associated with much larger fixtures
 - Ultra compact – 704 x 501 x 320mm – 33kg (28 x 20 x 13in – 73lb)
 - Feature loaded for mid-air effects, 4 beam reduction + 8 beams shapes fixed apertures gobos + 8 fully rotating gobos
 - Exclusive VL*FX animation wheel system, that creates dynamic new projected and mid-air effect
 - Dual overlay prism system
 - Image softening, variable 1° frost
 - Wash mode
 - Endless color options, CMY color mixing + fixed color wheel
 - Ready to tour, ship complete with SIP insert



Note: For more information and product specifications, refer to [“Technical Specifications”](#) on page 67.



Features

Included Items

The following illustration shows all items included with the luminaire:

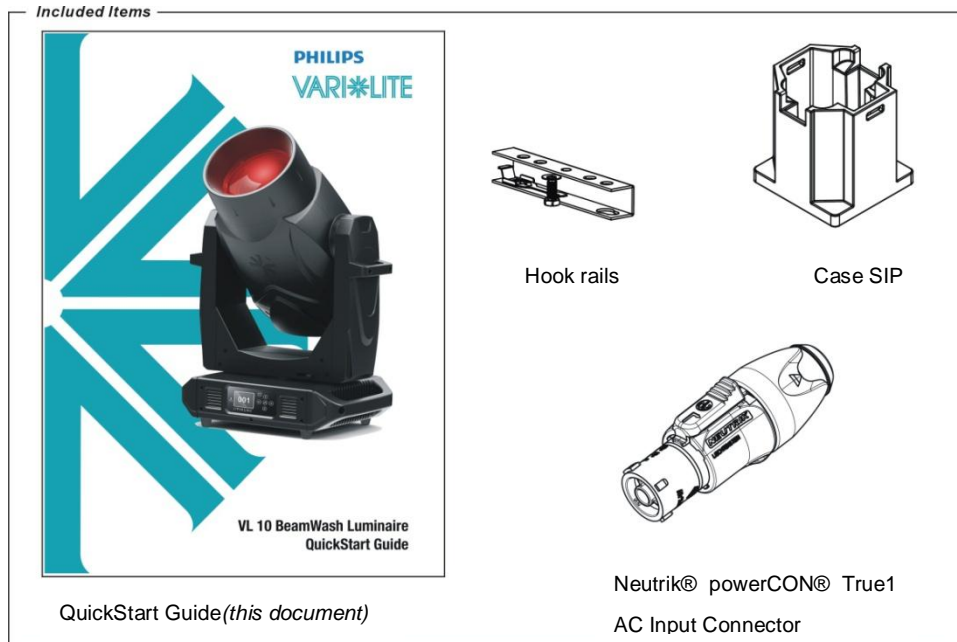
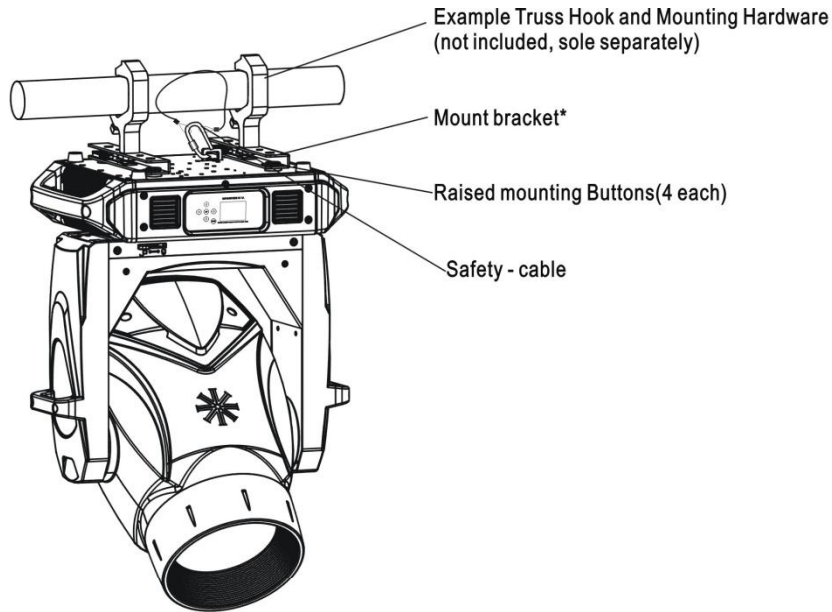

Figure 1-1: VL10 BeamWash Included Items

Note: * Please Check with the Authorized Vari*Lite dealer for availability on accessories.

Luminaire Overview

The following illustration shows the external luminaire components and controls.



Fit bracket's keyed hole and locking mechanism over raised mounting buttons and slide forward.

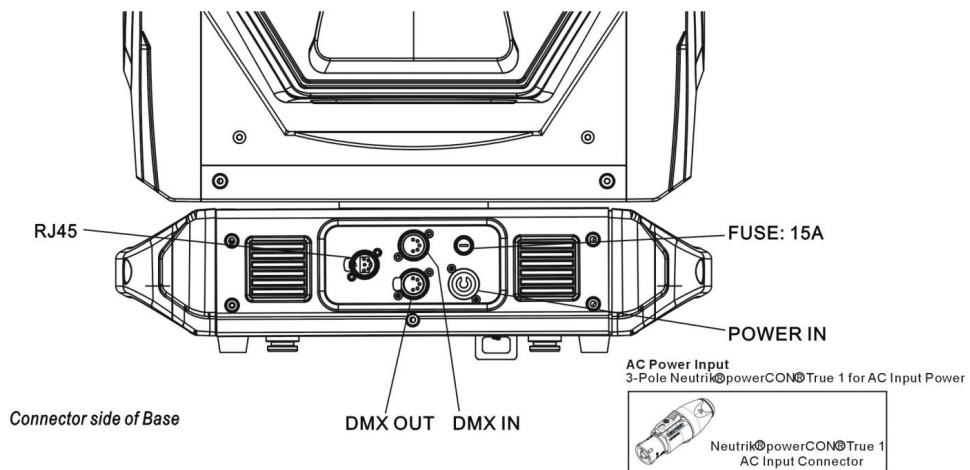
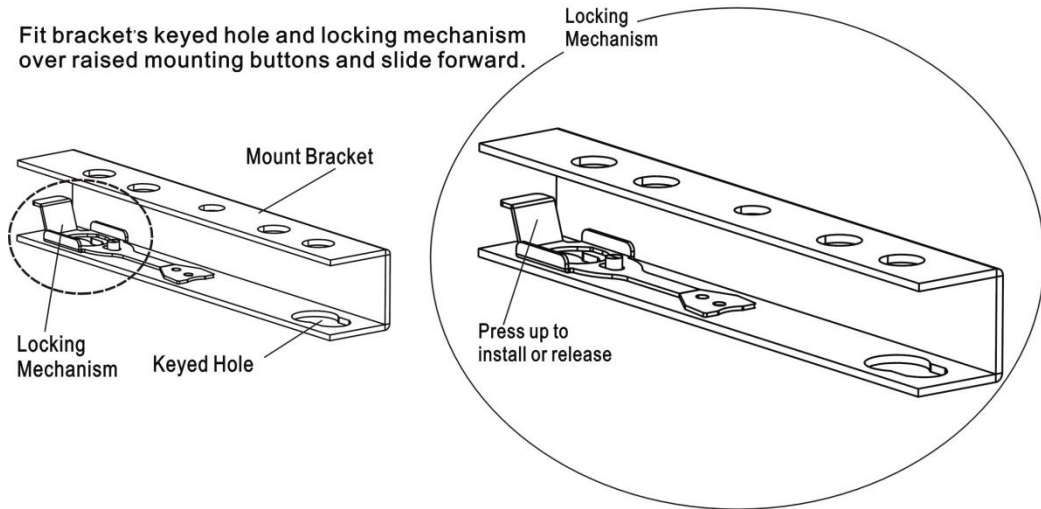

Notes

CHAPTER 2.

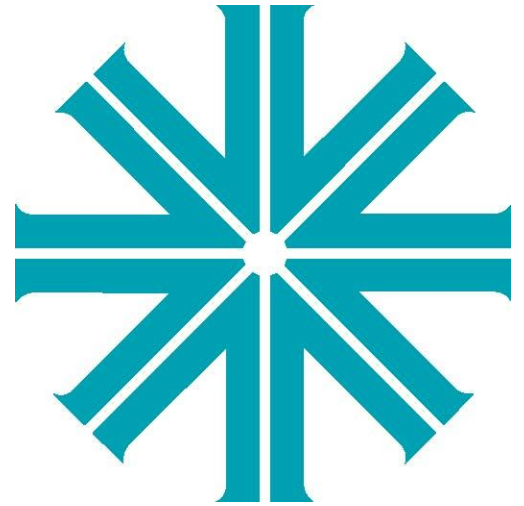

Installation

This chapter contains instructions for installation of the luminaire. It includes connecting power and data, along with instructions for powering up the luminaire for the first time and addressing it within your system.

- [Special Warnings](#)
- [Power and Data Cabling Requirements](#)
- [Installation Procedures](#)
- [Powering Up](#)
- [Addressing](#)

Special Warnings

Exceptional Safety Information for the VL10 BeamWash

The light intensity and power density of the VL10 BeamWash exceeds that of other fixtures typically used in this application. The warnings and cautions that follow are critically important to the safe operation of this fixture. This product is for commercial use only by trained professionals only.

If you have any questions about the safe installation and operation of the VL10 BeamWash, please contact Vari-Lite customer service at 1-877-VARI-LITE (1-877-827-4548), +1-214-647-7880, or entertainment.service@signify.com.



WARNING: Light Beam Projects Intense Heat. Do not illuminate objects within 15 m (49.21 feet) of the VL10 BeamWash. Objects within this range can scorch, melt, or ignite from the heat projected by the light beam.



WARNING: High Intensity Light Output. Do not look directly into the light beam. Avoid looking at nearby surfaces illuminated by the beam. It is hazardous to operate luminaires without lens or shield. Shields, lenses, or ultraviolet screens must be changed if they have become visibly damaged to such an extent that their effectiveness is impaired. For example, by cracks, deep scratches, or coating breakdown.



WARNING: Hot Exterior Surfaces. The exterior surfaces of the luminaire can get very hot - up to 120°C (248°F). Do not touch any surface of the luminaire while it is operating. Keep all combustible materials a minimum of 200 mm (7.87 inches) away from the luminaire. To maintain cooling fan operation after the lamp is doused, keep the luminaire powered on for 10 minutes. Wait an additional 10 minutes before touching the luminaire.



WARNING: Operating Environment. Do not operate the luminaire when the ambient temperature exceeds 45°C (113°F).



WARNING: Approved lamp Type. Use only approved lamp types in VL10 BeamWash. Users can check the latest version of Vari-Lite Technical Notice TN-248, on the Vari-Lite web site, for all approved lamp.

Power and Data Cabling Requirements

Power

The luminaire requires standard AC power distribution from AC100-240V~, 50/60Hz. Current required depends on the AC supply voltage and product model.



Note: The mating Neutrik PowerCon connector is supplied, however, you will need to purchase or construct a cable appropriate for your application.

Allow one hour warm up if ambient temperature is below 10°C (50°F) .

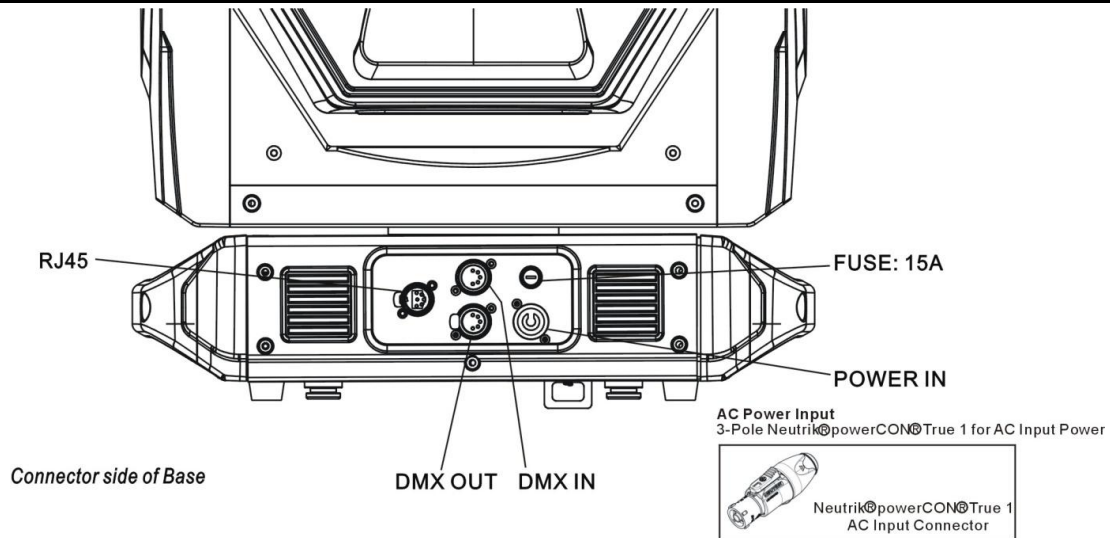

Figure 2-1: Power Connector

Depending on the application, the luminaire’s AC input cable may require a different connector. If required, install a new connector meeting your requirements using the following wire color code reference:

Wire*	Connection
Green	AC Ground
White	AC Neutral
Black	AC Line
* International (Harmonized) Standard	



WARNING: DO NOT connect to three-phase service in countries with 240 volt power.

AVERTISSEMENT: NE PAS se connecter au service en trois phases dans les pays avec puissance de 240 volts.

For single-phase power at 240 volts RMS:

Connection	Pin
AC Neutral	N
AC Line	L
Ground(Earth)	G



WARNING: It is not recommended to power any VARI*LITE luminaire from a dimmer - even in 'NONDIM' mode. Dimmer and non-dim modules are not suitable sources of power because their output modifies the AC wave form. This may work for a short time, but will eventually result in power problems, luminaire mis-operation and/or failure and may void the luminaire's warranty.

DMX Termination Connector

A DMX termination connector is required at the last luminaire (or "far end of the line") to prevent signal reflections. Signal reflections may cancel out the signal at certain line lengths, resulting in errors. The terminator is also necessary for software downloads and running tests on multiple luminaires. To construct your own connector, you will need the following components:

- 5-pin, male XLR connector.

Note: A DMX termination connector assembly is available as an accessory from Vari-Lite.

Installation Procedures

Hanging the Luminaire

The VL10 BeamWash can be hung horizontally or vertically from any structure designed to work with the type of load created by this moving luminaire. Two mounting truss hooks or other mounting hardware are required. Many compatible truss hooks are available from different manufacturers for your particular needs. A minimum of two hooks per luminaire is required. If mounting method does not use truss hooks, two attachment points, per luminaire, are required.

Install mounting hardware and brackets:

Step 1. Install truss hooks on two provided truss hook brackets as required as shown in **Figure 2-2**.

Step 2. Determine required configuration of bracket installation. Brackets may be installed in many different orientations as shown in **Figure 2-3**.

Step 3. While pulling up on locking mechanism release, fit keyed holes onto raised mounting buttons at bottom of enclosure. Slide forward and release locking mechanism to lock in place. Ensure brackets are locked securely.

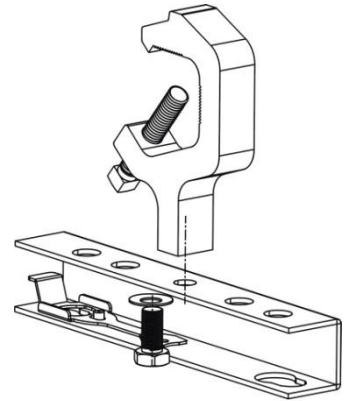

Figure 2-2: Truss Hook Installation



WARNING: Ensure that the bracket locking mechanism is fully seated after the bracket is installed on the luminaire.

AVERTISSEMENT: Assurez-vous que le mécanisme de support de verrouillage est complètement inséré après le support est installé sur l'appareil.

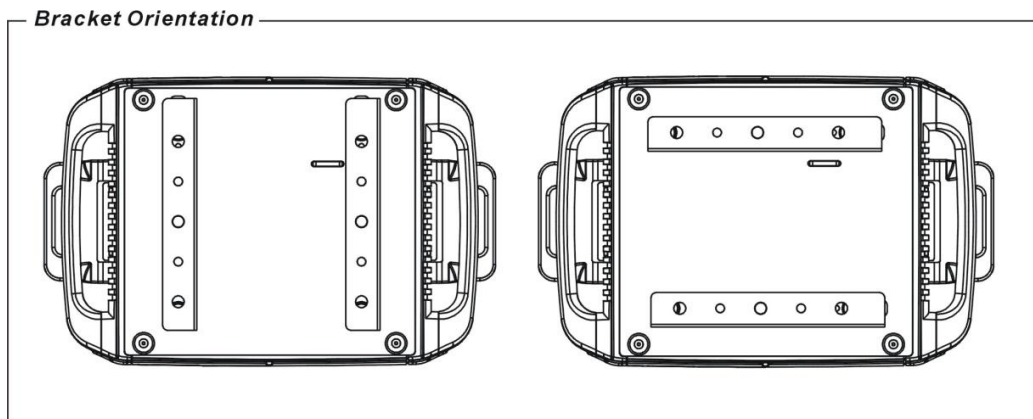
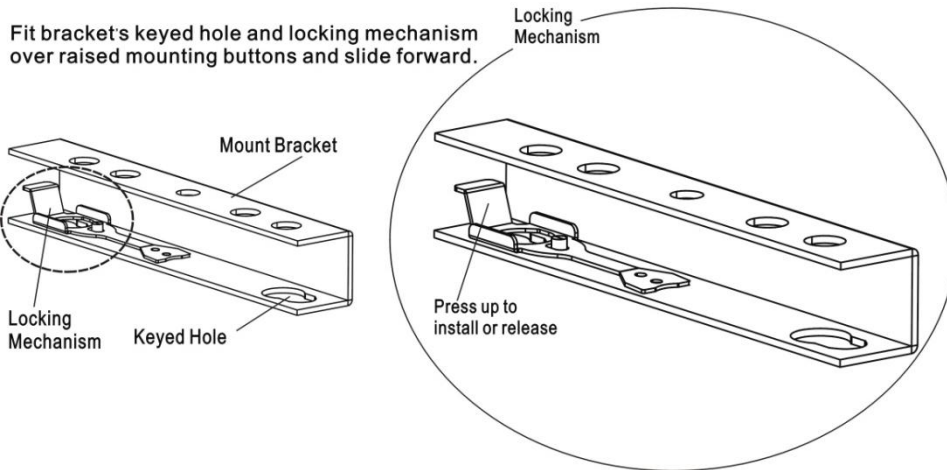
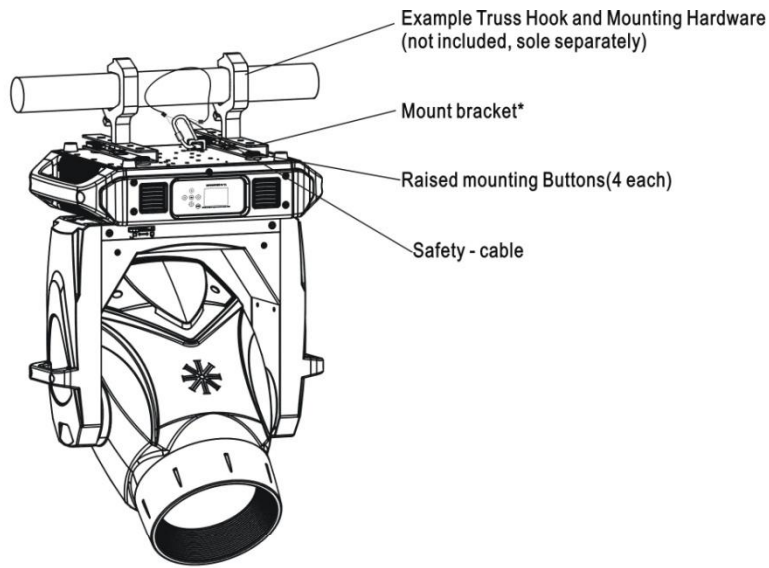

Figure 2-3: Installing Brackets on Luminaire Enclosure

Floor Mounting the Luminaire

All luminaires included in this manual are designed to sit directly on its base in a floor installation application. When used in this type of application, be sure to leave enough space around the luminaire to allow proper, uninterrupted airflow for cooling and movement.



WARNING: Light Beam Projects Intense Heat. Do not illuminate objects within 15 m (49.21 feet) of the VL10 BeamWash. Objects within this range can scorch, melt, or ignite from the heat projected by the light beam.

Connecting Data and Power

A maximum of 12 luminaires may be connected in any one DMX data link.

Note: This maximum limit applies to the luminaire "daisy chain" only. Your system or console may require fewer luminaires on a single data link path. Consult your console documentation for more information.

To connect power and data:

- Step 1. Connect data cable from console to first luminaire in chain at DATA IN connector.
- Step 2. If required, connect additional data cables from DATA THRU connectors to DATA IN connectors of remaining luminaires in link.
- Step 3. At last luminaire in link, install male termination connector at DATA THRU connector. (Luminaires and other devices on the same DMX chain may not function properly without termination.)

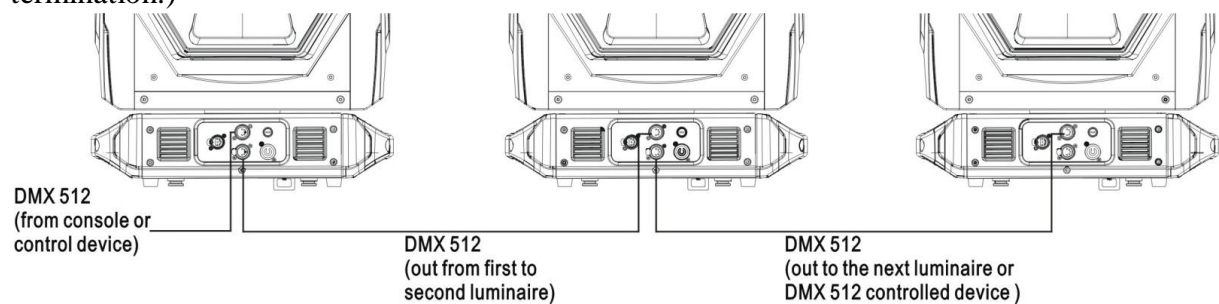

Figure 2-4: Data Link

- Step 4. Connect AC Input Cable connector to power input source.
- Step 5. Dress AC input and data cables and secure them so that they will not interfere with luminaire head and yoke movement.

Powering Up

Power Up and Configuration Procedure

The internal color, gobo, and beam mechanisms will also move through a full range of motion. After calibration, the luminaire head will either stop at its "home" position (which positions the pan axis at mid-rotation and the head parallel to the yoke with the lens pointing away from the luminaire upper enclosure) or move to its current DMX-defined position if DMX data is present. All internal mechanisms also move to their "home" or DMX-defined positions.

Subsequently, depending on the luminaire's setting for Power-Up State (refer to [“VL10 BeamWash Menu System Function Chart”](#) on page 54).



CAUTION: Before applying power, be sure the luminaire is hung or positioned so that the head and yoke can move freely without restriction. Make sure service tilt and pan locks are disengaged so luminaire moves freely.

To power up:

At each luminaire, apply power by connecting luminaire to input power source (100 to 240VAC). Luminaire will automatically step through following procedure:

- a. Luminaire will cycle through calibration and stop at "home" position.

Addressing

Program Starting Address



The address setting for DMX console controlled systems is entered using the Menu Display (refer to [“Menu Operation” on page 52](#)). The luminaire retains the DMX address even if power is removed.





Note: Refer to your console operating instructions for specific information regarding its addressing requirements.

Program a DMX starting address:

Step 1. Power unit on (either via mains or battery)

Step 2. Press  to access menu





Step 3. Press  or  to access ADDRESS and press 

Step 4. Use  or  to move cursor to Hundreds, Tens or Ones...then press  or  to select desired digit. Note it will scroll from 9 to 0 or 0 to 9. Once all three digits are set, press  to accept

Program Starting Address Without Calibrating Luminaire

It is possible to bypass the calibration sequence and go directly to the Menu Display programming in order to pre-program an address setting.

Program starting address without calibrating luminaire:

- While powering up luminaire, press and hold . Program address as in Program Starting Address above.
 - Press and hold  until display changes to the DMX address.
 - Or boot via battery. Press  and  at the same time until display boots
-

Note: The luminaire will require a reset to restore control. See [“VL10 BeamWash Control Channel Functions” chapter on page 28](#) for control channel information on luminaire reset.

CHAPTER 3.

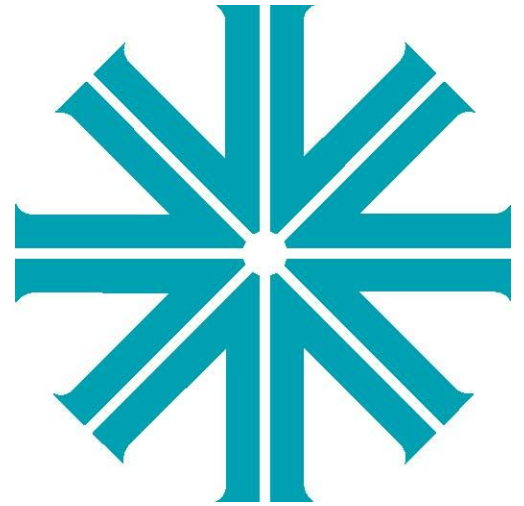

Operation

This chapter contains instructions for operating the luminaire using DMX control and for updating the internal software.

[VL10 BeamWash DMX Channels](#)

[VL10 BeamWash DMX Mapping](#)

[VL10 BeamWash Luminaire Timing](#)

[Updating Software](#)

VL10 BeamWash DMX Channels

VL10 BeamWash Channel Mapping

These tables assume a DMX start address of 1. When a different starting address is used, this address becomes channel 1 function and other functions follow in sequence.

Table 3-1: VL10 BeamWash DMX Channel Mapping

16 - Bit Enhanced / 16 - Bit DMX channel's functions and their values (41/ 36 DMX channels):

DMX		Parameter	Range DMX	Range %	Defaults*	Description	Notes		
16 - Bit Enhanced	16 - Bit								
1	1	Intensity	0-65535	0-100%	0	16 Bit Dimming			
2	2								
3	3	Pan High	0-65535	0-100%	32767	Fixture Pan -	540° Total Pan Rotation		
4	4	Pan Low							
5	5	Tilt High	0-65535	0-100%	32767	Fixture Tilt -	270° Total Tilt		
6	6	Tilt Low							
7	7	Focus High	0-65535	0-100%	TBC	16 Bit Focus Control	Default should be fixture in focus as open spot in default zoom @ 6m distance		
8	8	Focus Low							
9	9	Zoom High	0-65535	0-100%	0	16 Bit Zoom control			
10	10	Zoom Low							
11	11	Cyan	0 - 255	0-100%	0	0	Control of cyan color mechanism.		
12	12	Yellow	0 - 255	0-100%	0	0	Control of yellow color mechanism.		
13	13	Magenta	0 - 255	0-100%	0	0	Control of Magenta color mechanism.		
14	14	Color Wheel	0 - 255	0-100%	0	0	8-bit control of Color Wheel. (spin speed slow to fast from control channel)		
			0					→	OPEN (centred at 0)
			22-26					→	Color 1 RED Centre 25
			45-49					→	Color 2 BLUE Centre 47
			69-73					→	Color 3 YELLOW Centre 71
			92-96					→	Color 4 KELLY GREEN Centre 94
			115-119					→	Color 5 MAGENTA Centre 94
		138-142	→	Color 6 CTO Centre 140					

DMX		Parameter	Range DMX	Range %	Defaults*	Description	Notes
16 - Bit Enhanced	16 - Bit						
			162-166 185-189 208-212 231-235 236-355			→ → → → →	Color 7 LAVENDER Centre 164 Color 8 GREEN Centre 187 Color 9 AMBER Centre 210 Color 10 CONGO BLUE Centre 233 Open Centre @ 225
15	15	Color Wheel Control	0 - 255	0-100%	0	0	Used as a control channel for different movement options of Color Wheel 1. 0 - 5 → Linear Movement using shortest (quickest) path. 6 - 10 → Linear Movement using normal (longest) path. 11 - 15 → Wheel Spin CW Forward 16 - 20 → Wheel Spin STOP 21 - 25 → Wheel Spin CCW Reverse 26 - 56 → Color Shake Shortest Path (Slow to Fast) 57 - 87 → Color Shake Normal Path (Slow to Fast) 88 - 255 → Reserved Values
16	16	Gobo Wheel 1 (aperture wheel Fixed)	0 - 255	0-100%	0	0	8-bit control of Gobo Wheel 1. See Channel 21 for control options. 0 - 5 → Open 6 - 10 → Aperture hole EXTRA SMALL 11 - 15 → Aperture hole SMALL 16 - 20 → Aperture hole MEDIUM 21 - 25 → Aperture hole LARGE 26 - 30 → Aperture HORIZONTAL BAR 31 - 35 → Aperture HORIZONTAL SLITS 36 - 40 → Aperture 3 DOT SPLIT 41 - 45 → Aperture SPLIT CONE 46 - 50 → Aperture PEACE 51 - 55 → Aperture BAR BREAK 56 - 60 → Aperture VERTICAL SLITS

VARI*LITE VL10 BeamWash User's Manual

DMX		Parameter	Range DMX	Range %	Defaults*	Description	Notes
16 - Bit Enhanced	16 - Bit						
			61 - 65 66 - 225			→ →	Aperture CLOVER Reserved
17	17	Gobo Wheel 1 Control	0 - 255	0-100%	0	0	Used as a control channel for different movement options for Gobo Wheel 1 (Channel 17). Gobo Selection using shortest (quickest) path. Gobo Selection using normal (longest) path. Reserved Values Wheel Spin CW Forward (Fast to Slow) Wheel Spin STOP Wheel Spin CCW Reverse (Slow to Fast) Gobo Shake Shortest Path (Slow to Fast) Gobo Shake Normal Path (Slow to Fast) Reserved Values Reserved Values Reserved Values
18	18	Gobo Wheel 2	0 - 255	0-100%	0	0	8-bit control of Gobo Wheel 2. See Channel 25 for control options. Open - No Gobo Gobo 1 Index CIRCLE SPACE VL10 Gobo 2 Index DOUBLE 3 HOLE VL10 Gobo 3 Index PSYCLONE VL10 Gobo 4 Index CROSSED BAR VL10 Gobo 5 Index RAY GEAR VL10 Gobo 6 Index PUNCHCARD VL10 Gobo 7 Index SHOCK BREAKUP VL10 Gobo 8 Index ROOS OVAL VL10 Open - No Gobo

DMX		Parameter	Range DMX	Range %	Defaults*	Description	Notes
16 - Bit Enhanced	16 - Bit						
			51 - 55			→	Gobo 1 Rotate CIRCLE SPACE VL10
			56 - 60			→	Gobo 2 Rotate DOUBLE 3 HOLE VL10
			61 - 65			→	Gobo 3 Rotate PSYCLONE VL10
			66 - 70			→	Gobo 4 Rotate CROSSED BAR VL10
			71 - 75			→	Gobo 5 Rotate RAY GEAR VL10
			76 - 80			→	Gobo 6 Rotate PUNCHCARD VL10
			81 - 85			→	Gobo 7 Rotate SHOCK BREAKUP VL10
			86 - 90			→	Gobo 8 Rotate ROOS OVAL VL10
			91 - 95			→	Open - No Gobo
			96 - 100			→	Gobo 1 MegaStep CIRCLE SPACE VL10
			101 - 105			→	Gobo 2 MegaStep DOUBLE 3 HOLE VL10
			106 - 110			→	Gobo 3 MegaStep PSYCLONE VL10
			111 - 115			→	Gobo 4 MegaStep CROSSED BAR VL10
			116 - 120			→	Gobo 5 MegaStep RAY GEAR VL10
			121 - 125			→	Gobo 6 MegaStep PUNCHCARD VL10
			125 - 130			→	Gobo 7 MegaStep SHOCK BREAKUP VL10
			131 - 135			→	Gobo 8 MegaStep ROOS OVAL VL10
			136 - 225				Reserved
19	19	Gobo 2 Rot/Index High Byte	0 - 65535	0-100%	0	32767	16-bit control of index and rotation of gobo wheel 1.
20	20	Low Byte	0 - 32756			→	Rotate Slow to Fast <<<
			32757 - 32780			→	Rotation STOP
			32781 - 65535			→	Rotate Slow to Fast >>>
21	21	Gobo Wheel 2	0 - 255	0-100%	0	0	Used as a control channel for different movement options for

VARI*LITE VL10 BeamWash User's Manual

DMX		Parameter	Range DMX	Range %	Defaults*	Description	Notes
16 - Bit Enhanced	16 - Bit						
		Control	0 - 5 6 - 10 11 - 20 21 - 50 51 - 60 61 - 90 91 - 120 121 - 150 151 - 180 181 - 210 211 - 255			→ → → → → → → → → → →	Gobo Wheel 1 (Channel 17). Gobo Selection using shortest (quickest) path. Gobo Selection using normal (longest) path. Reserved Values Wheel Spin Forward (Fast to Slow) Wheel Spin STOP Wheel Spin Reverse (Slow to Fast) Gobo Shake Quickest Path (Slow to Fast) Gobo Shake Normal Path (Slow to Fast) Gobo Twist Shortest Path (Slow to Fast) Gobo Twist Normal Path (Slow to Fast) Reserved Values
22	22	VLFX Wheel	0-255 0 - 5 6 - 10 11 - 15 16 - 20 21 - 25 26 - 30 31 - 35 36 - 40 41 - 45 46 - 50	0-100%	0	0 → → → → → → → → → →	8-bit control of Gobo Wheel 3. Open - Animation Wheel 1 Index DICHROFUSION Animation Wheel 1 Index CONCURRENT Animation Wheel 1 Index WICKED WAVES Animation Wheel 1 Index CONCENTRIC Animation Wheel 1 Index ON THE ROCK Open - Animation Wheel 1 Rotation DICHROFUSION Animation Wheel 1 Rotation CONCURRENT Animation Wheel 1 Rotation WICKED WAVES

DMX		Parameter	Range DMX	Range %	Defaults*	Description	Notes
16 - Bit Enhanced	16 - Bit						
			51 - 55			→	Animation Wheel 1 Rotation CONCENTRIC
			56 - 60			→	Animation Wheel 1 Rotation ON THE ROCK
			61 - 65			→	Open -
			66 - 70			→	Animation Wheel 1 MegaStep DICHROFUSION
			71 - 75			→	Animation Wheel 1 MegaStep CONCURRENT
			76 - 80			→	Animation Wheel 1 MegaStep WICKED WAVES
			81 - 85			→	Animation Wheel 1 MegaStep CONCENTRIC
			86 - 90			→	Animation Wheel 1 MegaStep ON THE ROCK
			91 - 255			→	Reserved
23	23	Gobo 3 Rot/Index High Byte	0 - 65535	0-100%	0	32767	16-bit control of index and rotation of gobo wheel 1.
24	24	Low Byte	0 - 32756			→	Rotate Slow to Fast <<<<
			32757 - 32780			→	Rotation STOP
			32781 - 65535			→	Rotate Slow to Fast >>>>
25	25	Gobo Wheel 3 Control	0 - 255 Gobo Wheel 2 - 2	0-100%	0	0	Used as a control channel for different movement options for Gobo Wheel 3 (Channel 26).
			0 - 5			→	Gobo Selection using shortest (quickest) path.
			6 - 10			→	Gobo Selection using normal (longest) path.
			11 - 20			→	Reserved Values
			21 - 50			→	Wheel Spin Forward (Fast to Slow)
			51 - 60			→	Wheel Spin STOP
			61 - 90			→	Wheel Spin Reverse (Slow to Fast)
			91 - 120			→	Gobo Shake Quickest Path (Slow to Fast)

VARI*LITE VL10 BeamWash User's Manual

DMX		Parameter	Range DMX	Range %	Defaults*	Description	Notes
16 - Bit Enhanced	16 - Bit						
			121 - 150 151 - 180 181 - 210 211 - 255			→ → → →	Gobo Shake Normal Path (Slow to Fast) Gobo Twist Shortest Path (Slow to Fast) Gobo Twist Normal Path (Slow to Fast) Reserved Values
26	26	Prism 1 Triangular Prism	0 - 255 0 - 5 6 - 10 11 - 15 16 - 20 21 - 255		0 - 255	0 → → → → →	Controls Prism mechanism with following values. Open Index Rotate Normal Rotate with Mega Stepping Reserved Values
27 28	27 28	Prism Index/Rot High Byte Low Byte	0-65535 0 - 32756 32757 - 32780 32781 - 65535	0-100%	0 - 65535	32767 → → →	16-bit control of prism rotation and index. Rotate Slow to Fast <<< Rotation STOP Rotate Slow to Fast >>>
29	29	Prism 2 Triangular Prism	0 - 255 0 - 5 6 - 10 11 - 15 16 - 20 21 - 255		0 - 255	0 → → → → →	Controls Prism mechanism with following values. Open Index Rotate Normal Rotate with Mega Stepping Reserved Values
30 31	30 31	Prism Index/Rot High Byte Low Byte	0-65535 0 - 32756 32757 - 32780	0-100%	0 - 65535	32767 → →	16-bit control of prism rotation and index. Rotate Fast to Slow <<< Rotation STOP

DMX		Parameter	Range DMX	Range %	Defaults*	Description	Notes
16 - Bit Enhanced	16 - Bit						
			32781 - 65535			→	Rotate Slow to Fast >>>
32	32	Frost 1	0-255	0-100%	0		Linear control of frost mechanism from out (DMX 0) to full in (DMX 255)
33	33	Frost 2 (wash Mode)	0-255	0-100%	0		Linear control of frost mechanism from out (DMX 0) to full in (DMX 255)
34	34	Strobe Speed	0 - 255	0-100%	0	0	Controls strobe rate from slowest (DMX 0) to fastest (DMX 255)
35	35	Strobe Control	0 - 255	0-100%	0 - 255	0	Control Channel for strobing functions.
			0 - 5			→	Open
			6 - 10			→	Closed
			11 - 15			→	Normal Strobe
			16 - 20			→	Random Strobe
			21 - 25			→	Random Sync
			26 - 255			→	Reserved Values
36		Focus Timing	0 - 255		255	255	Adjustment of fixture timing to control Pan/Tilt mechanisms. - See Timing Channel Chart in User Manual
37		Optics Timing	0 - 255		255	255	Adjustment of fixture timing to control lensing mechanisms. - See Timing Channel Chart in User Manual
38		Color Timing	0 - 255		255	255	Adjustment of fixture timing to control color mechanisms. - See Timing Channel Chart in User Manual

VARI***LITE** VL10 BeamWash User’s Manual

DMX		Parameter	Range DMX	Range %	Defaults*	Description	Notes
16 - Bit Enhanced	16 - Bit						
39		Beam Timing	0 - 255		255	255	Adjustment of fixture timing to control beam shaping mechanisms. - See Timing Channel Chart in User Manual
40		Gobo Timing	0 - 255		255	255	Adjustment of fixture timing to control gobo mechanisms. - See Timing Channel Chart in User Manual
41	36	Luminaire Control	0 - 255		0	0	Control Channel used for full fixture settings, lamp controls, and miscellaneous modes. Set discrete value of desired effect, wait >3 seconds, then set value to 0 (Idle). 0 - 5 → Idle (Default) 6 - 10 → Full Luminaire ReCal 11 - 15 → Lamp On 16 - 20 → Lamp Off 21 - 25 → Fixture shutdown 26 - 30 → Display-Menu On 31 - 35 → Display-Menu Off 36 - 40 → ReCal Position 41 - 45 → ReCal Color 46 - 50 → ReCal Gobo 51 - 55 → ReCal Beam 56 - 60 → ReCal Optics 61 - 65 → Reserved (Future use) 66 - 70 → Reset Fixture to Defaults Full Luminaire Reboot This command will douse lamp and reset all processors in fixture, then ReCal all parameters. 71 - 75 → 76 - 80 → Fixture Status On/Off. This command will enable to display to show fixture status for 5 min. After this time, display return of default configurations. Repeating this command in less than 5 minutes will behave as a toggle

DMX		Parameter	Range DMX	Range %	Defaults*	Description	Notes
16 - Bit Enhanced	16 - Bit						
			81 - 85			→	Reserved Values
			86 - 90			→	Reserved Values
			91 - 95			→	Reserved Values
			96 - 100			→	Reserved Values
			101 - 105			→	Reserved Values
			111 - 115			→	Reserved Values
			116 - 120			→	Reserved Values
			121 - 125			→	Reserved Values
			126 - 225			→	Reserved Values
			126 - 130			→	Reserved Values
			131-135			→	Reserved Values
			136-255			→	Reserved Values

Notes:

- Default Values: Denotes recommended console default settings.
- Use of Timing Channels: The default value setting in the profile should be 255 (proportional control) to allow smooth movement when using console timing. The Timing channel data should change as a snap. A zero value will give the fastest move but without any smoothing, this can look steppy in console-timed moves.
- To use a timing channel instead of console timing it is necessary to set the timing channel to the desired value and set cue and/or parameter time to zero. A combination of time controls can produce unexpected results. Refer to [“VL10 BeamWash Timing Channel Information” on page 39](#) for more information.
- Timing Channel Control: The luminaire uses the timing channel value to calculate a smooth continuous movement for a given time and transition.

VL10 BeamWash Control Channel Functions

Control channel functions allow special actions such as reset and partial recalibration. These must be executed with zero time transition or with timing disabled. Discrete values must be used; not manual controls such as faders or encoders (see chart below for values).

Reset - resets all luminaire mechanisms.

Partial Recalibration - resets only the target mechanism (color, gobo, zoom, etc.) without affecting others.

Table 3-2: VL10 BeamWash Control Channel

DMX		Parameter	Range DMX	Range %	Defaults*	Description	Notes
16 - Bit Enhanced	16 - Bit						
41	36	Luminaire Control	0 - 255		0	0	Control Channel used for full fixture settings, lamp controls, and miscellaneous modes. Set discrete value of desired effect, wait >3 seconds, then set value to 0 (Idle).
			0 - 5			→	Idle (Default)
			6 - 10			→	Full Luminaire ReCal
			11 - 15			→	Lamp On
			16 - 20			→	Lamp Off
			21 - 25			→	Fixture shutdown
			26 - 30			→	Display-Menu On
			31 - 35			→	Display-Menu Off
			36 - 40			→	ReCal Position
			41 - 45			→	ReCal Color
			46 - 50			→	ReCal Gobo
			51 - 55			→	ReCal Beam
			56 - 60			→	ReCal Optics
			61 - 65			→	Reserved (Future use)
			66 - 70			→	Reset Fixture to Defaults
			71 - 75			→	
							Full Luminaire Reboot This command will douse lamp and reset all processors in fixture, then ReCal all parameters.
			76 - 80			→	Fixture Status On/Off. This command will enable to display to show fixture status for 5 min. After this time, display return of default configurations. Repeating this command in less than 5 minutes will behave as a toggle

DMX	DMX	Parameter	Range	Range %	Defaults*	Description	Notes
16 - Bit Enhanced	16 - Bit		DMX				
			81 - 85			→	Reserved Values
			86 - 90			→	Reserved Values
			91 - 95			→	Reserved Values
			96 - 100			→	Reserved Values
			101 - 105			→	Reserved Values
			111 - 115			→	Reserved Values
			116 - 120			→	Reserved Values
			121 - 125			→	Reserved Values
			126 - 225			→	Reserved Values
			126 - 130			→	Reserved Values
			131-135			→	Reserved Values
			136-255			→	Reserved Values

To use control channel functions:

Step 1. Select an action to be sent.

Step 2. Set control channel value for desired action (for example, 36 for ReCal). Hold value for 3 seconds.

Step 3. Set control channel value to zero. (This must occur without any scaling values. Action will be voided if other values are detected between action value and zero.)

Note: A numerical keypad is suggested for sending values. An encoder or fader does not allow for a quick value change, which is required to effect the control functions.

VL10 BeamWash DMX Mapping

VL10 BeamWash Color Control

The luminaire’s color system is composed of a CMY color mixing mechanism and one color wheel. The follow sections describe these components.

Color Mixing

The color mixing mechanism is made up of three graduated color flags: cyan, magenta and yellow. These flags provide full-spectrum color crossfades from pastel to saturated color.

Table 3-3: DMX Map for Cyan, Magenta and Yellow

DMX	Parameter	Range DMX	Range %	Defaults*	Description	Notes
11	Cyan	0 - 255	0-100%	0	0	Control of cyan color mechanism.
12	Yellow	0 - 255	0-100%	0	0	Control of yellow color mechanism.
13	Magenta	0 - 255	0-100%	0	0	Control of Magenta color mechanism.

Color Wheel

Color wheel offers timed changes, half and full frame positions, and various spin rates in either direction. The wheel contains ten slots, plus one open. The following illustration (Figure 3-1) shows the standard positions and color configuration for color wheel:

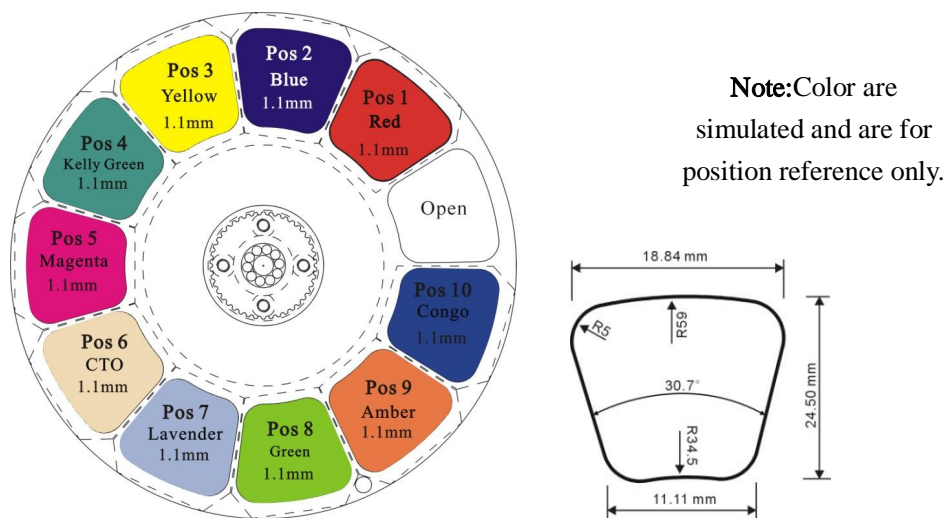

Figure 3-1: Color Wheel Standard Filters / Positions

Table 3-4: VL10 BeamWash Color Wheel Standard Configuration Chart

Position	Color Filter	Part Number
1	Red	6.03.05.03.1314
2	Drk Blue	6.03.05.03.2764
3	Yellow	6.03.05.03.1322
4	Kelly Green	6.03.05.03.2695
5	Magenta	6.03.05.03.1317
6	CTO	6.03.05.03.2698
7	Lavender	6.03.05.03.2705
8	Green	6.03.05.03.2706
9	Amber	6.03.05.03.2694
10	Congo	6.03.05.03.2765

Color Wheel DMX Map

Table 3-6: VL10 BeamWash DMX Map for Color Wheel

DMX	Parameter	Range DMX	Range %	Defaults*	Description	Notes
14	Color Wheel	0 - 255	0-100%	0	0	8-bit control of Color Wheel. (spin speed slow to fast from control channel)
		0			→	OPEN (centred at 0)
		22-26			→	Color 1 RED Centre 25
		45-49			→	Color 2 BLUE Centre 47
		69-73			→	Color 3 YELLOW Centre 71
		92-96			→	Color 4 KELLY GREEN Centre 94
		115-119			→	Color 5 MAGENTA Centre 94
		138-142			→	Color 6 CTO Centre 140
		162-166			→	Color 7 LAVENDER Centre 164
		185-189			→	Color 8 GREEN Centre 187
		208-212			→	Color 9 AMBER Centre 210
		231-235			→	Color 10 CONGO BLUE Centre 233
		236-355			→	Open Centre @ 225

VL10 BeamWash Beam Control

DMX Channel	Parameter	Range DMX	Defaults	Description
39	Beam Timing	0 - 255	255	Adjustment of fixture timing to control beam shaping mechanisms. - See Timing Channel Chart in User Manual

Strobe

Table 3-7: VL10 BeamWash DMX Map for Strobe

DMX Channel	Parameter	Range DMX	Defaults	Description
35	Strobe Control	0 - 255	0	Control Channel for strobing functions.
		0 - 5	→	Open
		6 - 10	→	Closed
		11 - 15	→	Normal Strobe
		16 - 20	→	Random Strobe
		21 - 25	→	Random Sync
		26 - 255	→	Reserved Values (Closed)

VL10 BeamWash Gobo/Effects Control

Overview of Gobos used in VL10 BeamWash

Due to the immense energy and light produced by VL10 BeamWash, Vari-Lite recommends to users and owners of this fixture follow the guidelines outlined below when loading gobos in any of the two rotating gobo wheels and one fixed gobo wheel.

Gobo Use and Positioning

Vari-Lite has purposely selected a set of standard gobos and gags for this fixture and positioned them within the fixture to offer optimum versatility / performance. The gobos supplied - in the standard factory configuration - have been tested in their respective original positions to protect their service life.

Note: For standard factory goboloads and position, please refer to the information contained in [“Gobo Wheels” on page 34](#) of this manual.

Users can load their own patterns (gobos). When using custom gobos, Vari-Lite recommends the following guidelines:

- Rotating gobo wheel 2 and VLFX Wheel have been designated the effects wheel. Should only house clear type gags or gobos that permit minimum unabated light transmission.
 - Rotating gobo wheel 2 Gobos are Metal, VLFX Wheel Gobos are Glass.
-



Note: Vari-Lite cannot guarantee the service life of any custom gobos when used in conjunction with this fixture. Owners and users employing custom gobos do so at their own risk.

Note: Animation wheel(VLFX) is locked out from being inserted into the beam when aperture wheel(gobo wheel1) is being used under beam mode.

Note: Aperture wheel(gobo wheel1) is locked out from being inserted into the beam when animation wheel(VLFX) is being used under beam mode.

Fixed Aperture Wheel (Gobo Wheel 1)

Fixed Aperture wheel have twelve slots, plus one open. Figure 3-3 illustrates the standard gobo configurations:

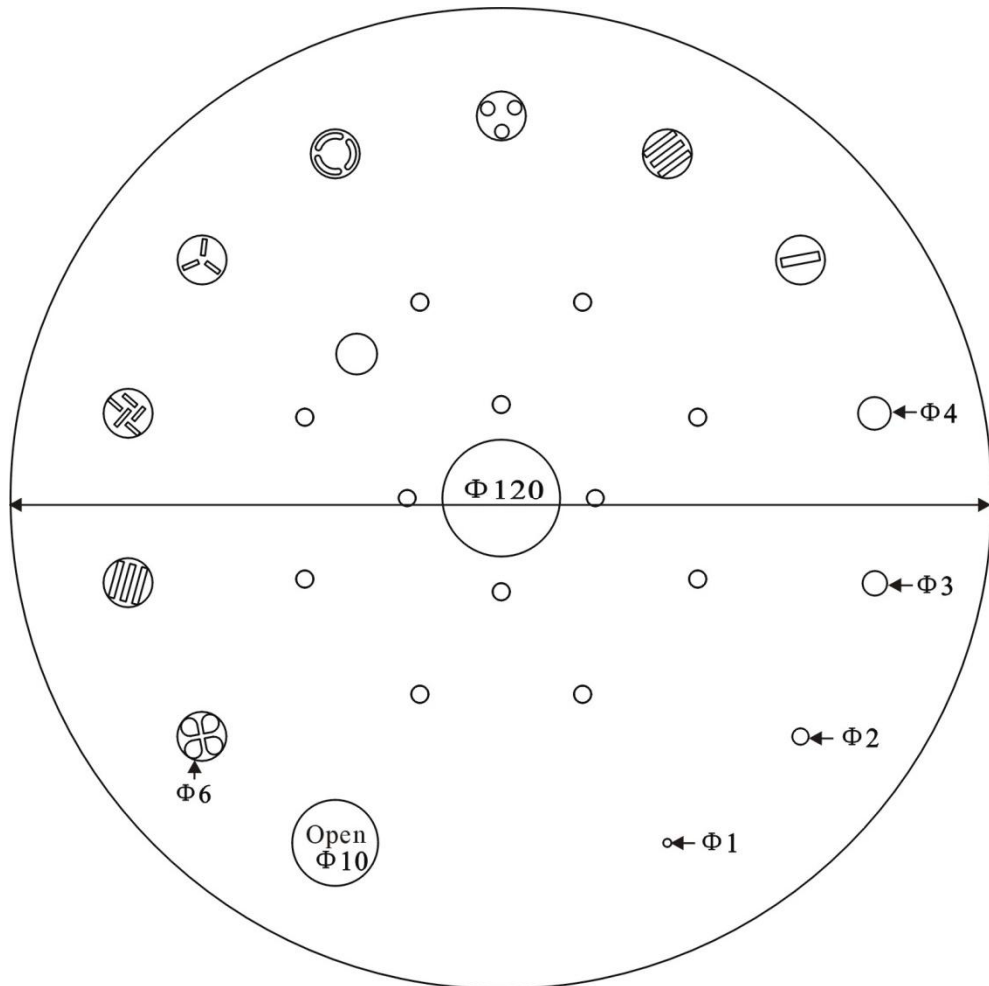

Figure 3-3: Gobo Wheel 1



Gobo Wheel 2

Rotating gobo wheel have eight slots, plus one open. Figure 3-4 illustrates the standard gobo configurations:

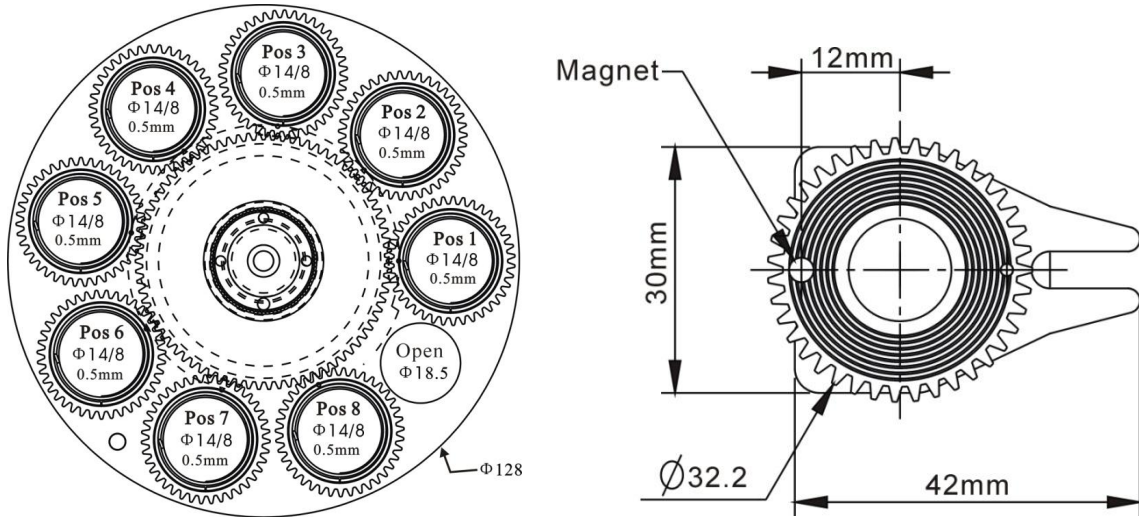

Figure 3-4: Gobo Wheel 2

For each wheel and their associated standard gobo, refer to Table 3-8

Table 3-8: VL10 BeamWash Gobo Wheel 1 Standard Configuration Chart

Position	Gobo Style	Part Number
	Open	No Gobo
1	VL-M509	6.03.03.05.1414
2	VL-M503	6.03.03.05.1408
3	VL-M504	6.03.03.05.1409
4	VL-M505	6.03.03.05.1410
5	VL-M506	6.03.03.05.1411
6	VL-M468	6.03.03.05.1523
7	VL-M507	6.03.03.05.1412
8	VL-M508	6.03.03.05.1413

Note: Raw artwork shown for gobos and gags is for reference only.



VLFX Wheel

VLFX Wheel have five slots, plus one open. Figure 3-5 illustrates the standard gobo configurations:

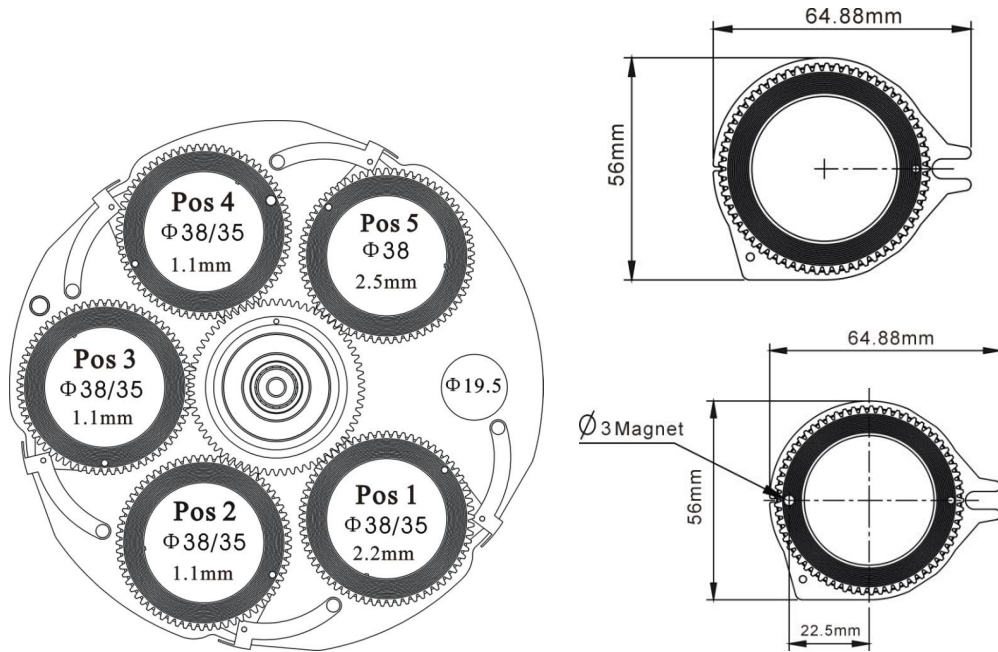

Figure 3-5: VLFX Wheel

For each wheel and their associated standard gobo, refer to Table 3-9

Table 3-9: VL10 BeamWash Gobo Wheel 2 Standard Configuration Chart

Position	Gobo Style	Part Number
	Open	No Gobo
1	VL-GD023 DICHROFUSION	6.03.03.06.0056
2	VL-GA337 CONCURRENT	6.03.03.01.1068
3	VL-GA336 WICKED WAVES	6.03.03.01.1067
4	GA149 CONCENTRIC	6.03.03.01.1069
5	VL-GB031 ON THE ROCK	6.03.03.03.0089

Note: Raw artwork shown for gobos and gags is for reference only.



VL-GD023 DICHROFUSION VL-GA337 CONCURRENT VL-GA336 WICKED WAVES GA149 CONCENTRIC VL-GB031 ON THE ROCK

Index and Rotation

The gobo wheels operate in two modes: INDEX Mode and ROTATE Mode. The corresponding values are given in the DMX Map Tables below. Gobos will also behave as follows:

- Gobo wheels will only stop at whole images.
- Timed moves are only available using the Gobo Time channel.
- Spins are variable from DMX 0-126 for CCW fast to slow, and 129-255 for CW slow to fast.
- The Gobo Index function utilizes 8-bit control which offers enhanced resolution whether in INDEX or ROTATE mode.

Table 3-10: VL10 BeamWash DMX Map for Gobo Wheel 2

DMX	Parameter	Range DMX	Range %	Defaults*	Description	Notes
18	Gobo Wheel 2	0 - 255	0-100%	0	0	8-bit control of Gobo Wheel 2. See Channel 25 for control options.
		0 - 5			→	Open - No Gobo
		6 - 10			→	Gobo 1 Index CIRCLE SPACE VL10
		11 - 15			→	Gobo 2 Index DOUBLE 3 HOLE VL10
		16 - 20			→	Gobo 3 Index PSYCLONE VL10
		21 - 25			→	Gobo 4 Index CROSSED BAR VL10
		26 - 30			→	Gobo 5 Index RAY GEAR VL10
		31 - 35			→	Gobo 6 Index PUNCHCARD VL10
		36 - 40			→	Gobo 7 Index SHOCK BREAKUP VL10
		41 - 45			→	Gobo 8 Index ROOS OVAL VL10
		46 - 50			→	Open - No Gobo
		51 - 55			→	Gobo 1 Rotate CIRCLE SPACE VL10
		56 - 60			→	Gobo 2 Rotate DOUBLE 3 HOLE VL10
		61 - 65			→	Gobo 3 Rotate PSYCLONE VL10
		66 - 70			→	Gobo 4 Rotate CROSSED BAR VL10
		71 - 75			→	Gobo 5 Rotate RAY GEAR VL10
		76 - 80			→	Gobo 6 Rotate PUNCHCARD VL10
		81 - 85			→	Gobo7Rotate SHOCK BREAKUP VL10
		86 - 90			→	Gobo 8 Rotate ROOS OVAL VL10
		91 - 95			→	Open - No Gobo
		96 - 100			→	Gobo 1 MegaStep CIRCLE SPACE VL10
		101 - 105			→	Gobo2MegaStepDOUBLE 3 HOLE VL10
		106 - 110			→	Gobo 3 MegaStep PSYCLONE VL10
		111 - 115			→	Gobo 4 MegaStep CROSSED BAR VL10
		116 - 120			→	Gobo 5 MegaStep RAY GEAR VL10
		121 - 125			→	Gobo 6 MegaStep PUNCHCARD VL10
		125 - 130			→	Gobo7 MegaStep SHOCK BREAKUP VL10
		131 - 135			→	Gobo 8 MegaStep ROOS OVAL VL10
		136 - 225				Reserved

Table 3-10: VL10 BeamWash DMX Map for Gobo Wheel 2

19	Gobo 2 Rot/Index	0 - 65535	0-100%	0	32767	16-bit control of index and rotation of gobo wheel 1.
	High Byte					
20	Low Byte	0 - 32756 32757 - 32780 32781 - 65535			→ → →	Rotate Slow to Fast <<< Rotation STOP Rotate Slow to Fast >>>

Table 3-11: VL10 BeamWash DMX Map for VLFX Wheel

DMX	Parameter	Range DMX	Range %	Defaults*	Description	Notes
22	VLFX Wheel	0-255	0-100%	0	0	8-bit control of Gobo Wheel 3.
		0 - 5			→	Open -
		6 - 10			→	Animation Wheel 1 Index DICHROFUSION
		11 - 15			→	Animation Wheel 1 Index CONCURRENT
		16 - 20			→	Animation Wheel 1 Index WICKED WAVES
		21 - 25			→	Animation Wheel 1 Index CONCENTRIC
		26 - 30			→	Animation Wheel 1 Index ON THE ROCK
		31 - 35			→	Open -
		36 - 40			→	Animation Wheel 1 Rotation DICHROFUSION
		41 - 45			→	Animation Wheel 1 Rotation CONCURRENT
		46 - 50			→	Animation Wheel 1 Rotation WICKED WAVES
		51 - 55			→	Animation Wheel 1 Rotation CONCENTRIC
		56 - 60			→	Animation Wheel 1 Rotation ON THE ROCK
		61 - 65			→	Open -
		66 - 70			→	Animation Wheel 1 MegaStep DICHROFUSION
		71 - 75			→	Animation Wheel 1 MegaStep CONCURRENT
		76 - 80			→	Animation Wheel 1 MegaStep WICKED WAVES
		81 - 85			→	Animation Wheel 1 MegaStep CONCENTRIC
		86 - 90			→	Animation Wheel 1 MegaStep ON THE ROCK
		91 - 255			→	Reserved
23	Gobo 3 Rot/Index	0 - 65535	0-100%	0	32767	16-bit control of index and rotation of gobo wheel 1.
		High Byte				
24	Low Byte	0 - 32756 32757 - 32780 32781 - 65535			→ → →	Rotate Slow to Fast <<< Rotation STOP Rotate Slow to Fast >>>

VL10 BeamWash Timing

VL10 BeamWash Timing Channel Information

Timing channel control improves the timed moves of certain groups of parameters. We provide up to four timing channels - Focus (pan and tilt), Optics Time (lens), Color Time (color parameters), Beam Time (beam parameters), and Gobo Time (gobo wheel operation).

Types of timing control:

- **Timing Control Channel:** the luminaire uses its timing channel value to calculate a smooth continuous movement for a given time and transition.
- **Console Timing:** the console calculates the time duration between the DMX increments to be sent for a given time and transition.
-

Guidelines:

- Timing channels support time values of up to six minutes.
- To use a timing channel instead of console timing, it is necessary to set the timing channel to the desired value and set cue and/or parameter time to zero. A combination of time controls can produce unexpected results.
- The default value setting in the profile should be 255 (proportional control) to allow smooth movement when using console timing.
- The timing channel data should change as a snap. A zero value will give the fastest move, however, without any smoothing this can appear "steppy" in console timed moves.

Note: Some parameters have been excluded from the timing channels. Wheel spin and gobo rotation rate changes are not affected by timing channels.

Table 3-12: VL10 BeamWash Channel Function / Timing Channel Relationship

DMX	Parameter	Range DMX	Range %	Defaults*	Description	Notes
36	Focus Timing	0 - 255		255	255	Adjustment of fixture timing to control Pan/Tilt mechanisms. - See Timing Channel Chart in User Manual
37	Optics Timing	0 - 255		255	255	Adjustment of fixture timing to control lensing mechanisms. - See Timing Channel Chart in User Manual
38	Color Timing	0 - 255		255	255	Adjustment of fixture timing to control color mechanisms. - See Timing Channel Chart in User Manual
39	Beam Timing	0 - 255		255	255	Adjustment of fixture timing to control beam shaping mechanisms. - See Timing Channel Chart in User Manual
40	Gobo Timing	0 - 255		255	255	Adjustment of fixture timing to control gobo mechanisms. - See Timing Channel Chart in User Manual

A timing value of zero is full speed. A time value of 100% (or DMX 255) enables the associated parameter(s) to follow cue fade time (console time) rather than the timing channel.

Note: The particular storing syntax for your console, as well as instructions on how to write part cues, can be found in the operation manual for that console.

To use these channels, you must:

- Step 1. Create the cue, including color, gobo, edge and frost as required.
- Step 2. Decide which fixtures and which parameter groups will use timing channels.
- Step 3. Assign a value to the particular timing channel(s) you wish to use (for timing information, see chart on next page).
- Step 4. Set console timing (or cue fade time) for parameters and timing channels to zero seconds.
- Step 5. Store cue.

Note: Avoid changing timing channel values in a fading cue. This can cause unexpected behavior in the luminaire as the timing channel value is updated over time. Timing channel values and the final destination of the parameters affected by the timing channel should always be sent in a zero count.

Timing channels can be set in either % or 0-255(DMX) modes, with the following values assigned:

Table 3-13:Timing Channels Map

DMX Value	% Values	Time (sec)
0		Full Speed
1		0.2
2		0.4
3	1	0.6
4		0.8
5	2	1
6		1.2
7		1.4
8	3	1.6
9		1.8
10	4	2
11		2.2
12		2.4
13	5	2.6
14		2.8
15	6	3
16		3.2
17		3.4
18	7	3.6
19		3.8
20	8	4

Table 3-13:Timing Channels Map (Continued)

DMX Value	% Values	Time (sec)
21		4.2
22		4.4
23	9	4.6
24		4.8
25	10	5
26		5.2
27		5.4
28	11	5.6
29		5.8
30		6
31	12	6.2
32		6.4
33	13	6.6
34		6.8
35		7
36	14	7.2
37		7.4
38	15	7.6
39		7.8
40		8
41	16	8.2
42		8.4
43	17	8.6
44		8.8
45		9
46	18	9.2
47		9.4
48	19	9.6
49		9.8
50		10
51	20	10.2
52		10.4
53		10.6
54	21	11
55		11
56	22	12
57		12
58		13
59	23	13

Table 3-13:Timing Channels Map (Continued)

DMX Value	% Values	Time (sec)
60		14
61	24	14
62		14
63		15
64	25	15
65		16
66	26	16
67		16
68		17
69	27	17
70		18
71	28	18
72		18
73		19
74	29	19
75		20
76	30	20
77		20
78		21
79	31	21
80		21
81		22
82	32	22
83		23
84	33	23
85		23
86		24
87	34	24
88		25
89	35	25
90		25
91		26
92	36	26
93		27
94	37	27
95		27
96		28

Table 3-13:Timing Channels Map (Continued)

DMX Value	% Values	Time (sec)
97	38	28
98		29
99	39	29
100		29
101		30
102	40	30
103		30
104		31
105	41	31
106		32
107	42	32
108		32
109		33
110	43	33
111		34
112	44	34
113		34
114		35
115	45	35
116		36
117	46	36
118		36
119		37
120	47	37
121		38
122	48	38
123		38
124		39
125	49	39
126		39
127		40
128	50	40
129		41
130	51	41
131		41
132		42
133	52	42

Table 3-13:Timing Channels Map (Continued)

DMX Value	% Values	Time (sec)
134		43
135	53	43
136		43
137		44
138	54	44
139		45
140	55	45
141		45
142		46
143	56	46
144		47
145	57	47
146		47
147		48
148	58	48
149		49
150	59	49
151		49
152		50
153	60	50
154		50
155		51
156	61	51
157		52
158	62	52
159		52
160		53
161	63	53
162		54
163	64	54
164		54
165		55
166	65	55
167		56
168	66	56
169		56
170		57

Table 3-13:Timing Channels Map (Continued)

DMX Value	% Values	Time (sec)
171	67	57
172		58
173	68	58
174		58
175		59
176	69	59
177		59
178		60
179	70	60
180		65
181	71	65
182		65
183		70
184	72	70
185		75
186	73	75
187		75
188		80
189	74	80
190		85
191	75	85
192		85
193		90
194	76	90
195		95
196	77	95
197		95
198		100
199	78	100
200		110
201	79	110
202		110
203		120
204	80	120
205		120
206	81	130
207		130

Table 3-13:Timing Channels Map (Continued)

DMX Value	% Values	Time (sec)
208		140
209	82	140
210		140
211		150
212	83	150
213		160
214	84	160
215		160
216		170
217	85	170
218		180
219	86	180
220		180
221		190
222	87	190
223		200
224	88	200
225		200
226		210
227	89	210
228		210
229		220
230	90	220
231		230
232	91	230
233		230
234		240
235	92	240
236		250
237	93	250
238		250
239		260
240	94	260
241		270
242	95	270
243		270
244		280

Table 3-13:Timing Channels Map (Continued)

DMX Value	% Values	Time (sec)
245	96	280
246		290
247	97	290
248		290
249		300
250	98	300
251		310
252	99	310
253		310
254		310
255	100	Follows Cue Data

Updating Software

Transferring Software From Luminaire to Luminaire

It is possible to transfer specific software versions between luminaires. As in the case of installing new software versions, multiple luminaires can be programmed at the same time if they are data linked together (refer to [“Connecting Data and Power” on page 14](#)), however a maximum of 12 luminaires can be updated at once.

Hardware Requirements

A DMX termination connector is used in this process. Refer to **page 16** for more information regarding the construction of this connector.

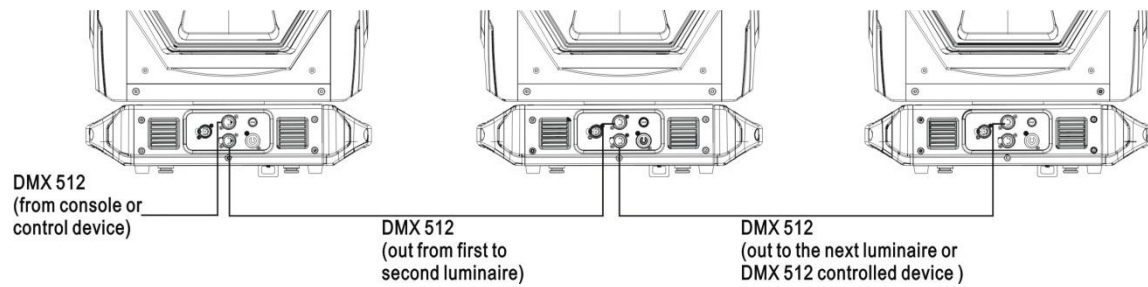

Figure 3-6: Software Transfer Setup

Transfer Procedure

This procedure is used to transfer software versions between luminaires.

Step 1. At last luminaire, install DMX termination connector into DATA THRU XLR connector.

Step 2. At master luminaire (first in chain) Menu Display, press **ESC**.

Step 3. Press **↑ ↓ ← →** arrows until Fixture appears.

Step 4. Press **↑ ↓ ← →** arrows until Crossload appears. Press **OK**.

Step 5. Unplug DMX From Console? will be displayed. Press **OK** to accept.

Step 6. Once download is complete, luminaire will automatically recalibrate. Once recalibration is complete, recalibrate luminaire one additional time.

Verify software version at luminaire:

Step 1. At Menu Display, press **ESC**.

Step 2. Press **↑ ↓ ← →** arrows until Fixture appears. Press **OK**.

Step 3. Press **↑ ↓ ← →** arrows until Version appears. Press **OK**.

Part 1 of the version will be displayed as VXXX.

Press **OK** to display part 2 of version. This will be displayed as a date (MM/DD/YY).

For example, 08/18/ 18 (August 18, 2018).

Press **OK** to display part 3 of version. This will be displayed as a time(HH:MM). For example, 16.36 (4:36 pm)

Notes

CHAPTER 4.

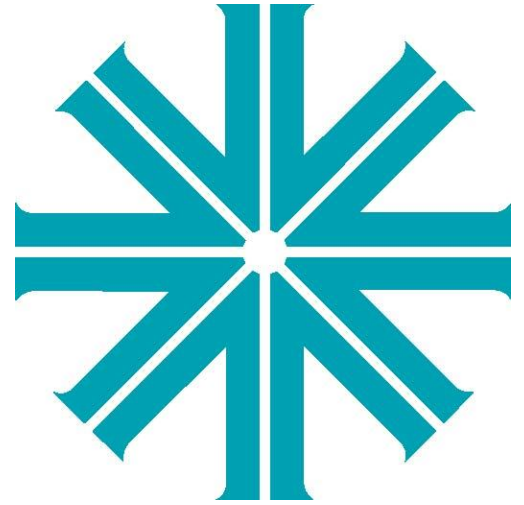

Menu System

This chapter contains instructions for operating the luminaire using the Menu Display feature.

- [Menu Operation](#)
- [Menu Functions](#)
- [Self-Tests](#)

Menu Operation

What Is the Menu System?

The menu system is a programmable set of commands used to configure, address, operate, and test the luminaire. The menu system is controlled at the Menu Display available at the enclosure input panel.



Figure 4-1: Menu Display Location

Controls Operation

The menu system is controlled by an **ESC**, **OK**, and four Arrow (**↑**, **↓**, **←**, **→**) buttons. These buttons function are shown in Figure 4-2.

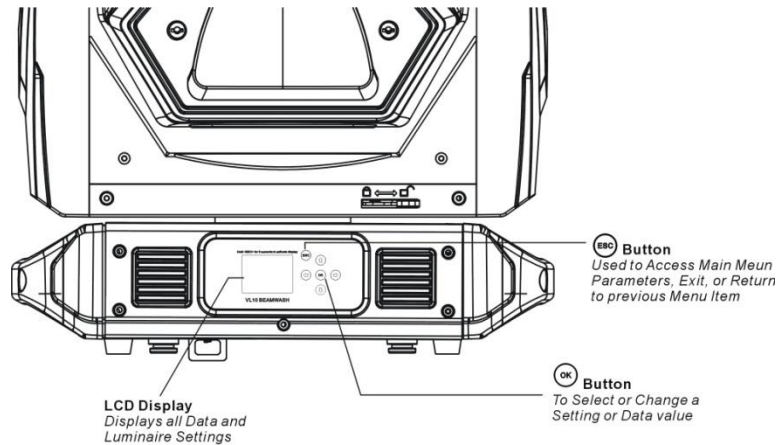

Figure 4-2: Menu Display Location

* The arrows will have opposite functions if the luminaire is hung upside down in a hanging orientation due to the automatic orientation feature. In other words, the arrow pointing downward always functions as down/decrease and the arrow pointing upward always functions as up/increase regardless of the luminaire orientation.

Default State

The menu display's default state during normal operation is to display the DMX address. After 40 seconds of inactivity at the display, it will change to the default state.





After longer periods of inactivity, the menu display will switch to its off state. The default state for this feature is 30 seconds, however, different time lengths can also be programmed.





To program a different time length for menu off feature:





Step 1. Press  access the main menu.





Step 2. Once enabled, the menu will function as normal with only the following sub-menu sections active:

- Address
- Configure
- DMX
- Fixture
- Manual Control
- Test

Step 3. Press     choose the "Configure", and press .

Step 4. Press     choose the "Display", and press .

Step 5. Press     choose the "On Time", and press .

Step 6. Press     choose "30 Sec", "5 Min", "10 Min", "On" when you need.

Menu Functions

VL10 BeamWash Menu System Function Chart

For easy reference, each possible menu item is listed alphabetically in the first column by its display abbreviation. The second column follows with a definition of the abbreviation and then a third column provides an explanation of its purpose and function.

Table 4-1: VL10 BeamWash Menu System Chart

Address	001~512			(Default 001)	
Configure	Lamp	Power	OFF	(Default)	
			ON		
		Power Up	OFF	(Default)	
			ON		
	Lamp Hours	XXXXXX h			
	Reset Lamp Hour	Are you sure?			
	Pan/Tilt	Movement	Enable	(Default)	
			Disable		
	Head Motors	Movement	Enable	(Default)	
			Disable		
	Display	Orientation	Auto	(Default)	
			Up		
			Down		
		On Time	30 Sec		
			5 Min	(Default)	
	10 Min				
	On				
	Reset Defaults	Are you sure?			
	Select Signal	DMX Only			(Default)
		Art-Net On IP2			
Art-Net On IP10					
Set Artnet	Set Universe	000~255	(Default 000)		
	Ethernet IP	XXX. XXX. XXX. XXX			
	Ether Mask IP	XXX. XXX. XXX. XXX			
DMX	Data	Channel 1 - Intensity = XXX (Value)			
		Channel 2 - Intensity Fine = XXX (Value)			
				
	Pan/Tilt	Swap Pan/Tilt	Off	(Default)	
			On		
Invert Pan		Off	(Default)		
	On				
Invert Tilt	Off / On		(Default Off)		
DMX Mode	16-bit Enh			(Default)	
	16-bit				

Note: When doing a disable head motors, the lamp will shut off automatically as a safety action since lamp cooling is related to shutter/strobe.

Table 4-1: VL10 BeamWash Menu System Chart

Fixture	Status	<i>(No Errors... or displays a list of errors)</i>		
	Recalibrate <i>(Fixture)</i>	Are you sure?		
	Reboot Fixture	Are you sure?		
	Version	VXXX	MM/DD/YY	HH:MM
	Fixture Hours	XXXXXX h		
	Crossload <i>(Software)</i>	Unplug DMX From Console?		
	Service	Service Settings	Set Position Cal	Pan
				Tilt
				Re. Pos. Offset
				ReCal Position
			Color Offset	Cyan
				Magenta
				Yellow
				Color Wheel
				Re. Col. Offset
				ReCal Color
			Gobo Offset	Gobo1 Wheel
				Gobo2 Wheel
				Gobo2 Rot
				Gobo3 Wheel
				Gobo3 Rot
Re. Gobo Offset				
Beam Offset			ReCal Gobo	
			Strobe	
			Re. Beam Offset	
Optics Offset			ReCal Beam	
	Focus			
	Zoom			
	Prism1			
	Prism2			
	Prism Rot			
	Prism2 Rot			
	Frost1			
	Frost2			
	Re. Opt. Offset			
ReCal Optics				
Diagnostics	Fan Check			
	Board Check			
	Sensor Check			
	Debug			
Manual Control	Intensity	Value 0 - 255	(Default 0)	
	Intensity fine	Value 0 - 255	(Default 0)	
	(Default 0)	
Test	All Test	<i>(Run 'ALL TEST')</i>		
	Pan/Tilt Test	<i>(Run 'PAN/TILT TEST')</i>		
	Test Channel	Intensity		(Run Intensity test)
		Pan		(Run Pan test)
	
	Encoder Pan	XXXXXXXX - Displays Pan Encoder		
Encoder Tilt	XXXXXXXX - Displays Tilt Encoder			

Self-Tests

Running Parameter Tests

The luminaire is capable of running self-tests by using the Testmenu functions.

When running tests on multiple luminaires, a DMX termination connector is required at the last luminaire in the link. Refer to [“Connecting Data and Power” on page 14](#) for more information regarding the construction of this connector.

Note: After 10 seconds of inactivity, the menu display will change to the default state showing the address.

Notes

APPENDIX A

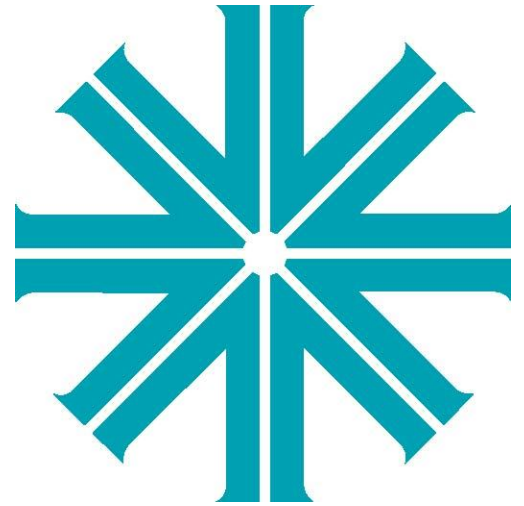

Luminaire Care and Routine Maintenance

This appendix provides instructions for troubleshooting and routine maintenance which may be necessary during the life of the luminaire.

- [Equipment Handling](#)
- [Troubleshooting](#)
- [Routine Maintenance](#)



WARNING: All maintenance procedures are to be performed with power removed from the luminaire. Never remove covers or backcap while LAMP is in operation.

Equipment Handling

Below are some basic tips and information on handling luminaires and their associated components.



Locations/Use

VARI*LITE luminaires are designed for dry locations only. Exposure to rain or moisture (including, but not limited to, fog machines, misters, etc.) may damage luminaire.

Lamps

Servicing

- When handling a lamp, hold it by the ceramic base while wearing cotton gloves or finger cots. Do not touch the glass envelope. If you touch the glass with bare fingers, immediately wipe off any fingerprints with isopropyl alcohol.
- Use care when opening and closing the rear castings (or covers) of luminaires and cleaning reflectors.

Heat

When lamp are lit, the interior of the luminaires becomes very hot. To aid in the airflow circulation within the luminaires, after dousing the lamp, wait ten minutes before removing power to the luminaires. This will provide enough time for the equipment fan to cool off the unit. Users should wait until the unit is cool to the touch before servicing or handling.

Lamp

- For optimal quality and performance, the cooling and power conditions during cold startup of the lamp must be optimized.
- If delayed cooling settings have been found, it should be verified that also during hot restrike, the TcTip and IR Top values remain within spec during run up. If no delayed cooling settings can be found that match both cold and hot run up situations, it is advised to modify the cooling down conditions after switch off.
- The criteria for reliable ignition is defined as a maximum of three ignition failures on 30 attempts per lamp.
- During the ignition phase of the lamp (0-80s) no cooling of the burner is recommended. Cooling of the burner can lead to ignition failure.
- When switching off the lamp, it is recommended to keep the cooling on until 30s after switch-off.
- Vari-Lite ignition reliability relies on multiple attempts (max. 5 for safety reasons) to start the lamp.
- The driver has a delay time of 15 sec after each ignition attempt. Therefore, it is advised to wait 15 sec between 2 attempts.
- For safety, the lamp will shut off automatically if there is a pan/tilt error on startup due to encoder is failing to read out the position of pan/tilt which is related to cooling system.

Solid State Electronics



Electrostatic Discharge (ESD)

Electrostatic discharge (ESD) presents a significant danger to solid state electronic components (semiconductor devices and PC board assemblies). Static electricity can build on a variety of common objects (including people) simply by handling or moving. ESD rarely results in immediate failure of a component, but shows up later as an intermittent problem or severely reduces the life of the component. All VARI*LITE equipment uses solid state electronics and appropriate precautions to protect them should be observed when servicing.

Printed Circuit Boards (PCBs)

All PC boards should be shipped in electrostatic shielding bags. When handling PC boards or components, devices such as conductive mats and conductive wrist straps should be used whenever possible. If these precautionary devices are not available, handling of PC boards and components should be avoided.



CAUTION: Black foam (used to package solid state electronics) should never be used for packing batteries or put in contact with PC boards which contain batteries.

Troubleshooting

Error Messages

If a problem occurs during luminaire calibration, at the end of the calibration sequence the Menu Display will cycle through any applicable error message(s) until the end of the list is reached. To review the error messages again, it will be necessary to access them using the Status function.

To access error messages:

Step 1. Press .

Step 2. Press     arrows until Fixture appears. Press .





Step 3. Press     arrows to access Status. Press . (Display will now scroll through any error messages or display OK if no errors.)

Table A-1: Error Messages

Display	Message
No Errors	Fixture is ok
NO Sensor On Pan	Pan sensor not found, Pan ReCalibrate fail. Note:For safety, the lamp will shut off automatically if there is a pan error on startup.
NO Sensor On Tilt	Tilt sensor not found, Tilt ReCalibrate fail. Note:For safety, the lamp will shut off automatically if there is a tilt error on startup.
NO Sensor On Cyan	Cyan sensor not found, Cyan ReCalibrate fail.
NO Sensor On Magenta	Magenta sensor not found, Magenta ReCalibrate fail.
NO Sensor On Yellow	Yellow sensor not found, Yellow ReCalibrate fail.
NO Sensor On Color Wheel	Color Wheel sensor not found, Color Wheel1 ReCalibrate fail.
NO Sensor On Rot Gobo1	Rotating Gobo1 sensor not found, Rotating Gobo1 ReCalibrate fail.
NO Sensor On Rot Gobo2	Rotating Gobo2 sensor not found, Rotating Gobo2 ReCalibrate fail.
NO Sensor On Gobo 2 Rot	Rotating Gobo2 Indexing sensor not found, Rotating Gobo2 Indexing ReCalibrate fail.
NO Sensor On Rot Gobo3	Rotating Gobo3 sensor not found, Rotating Gobo3 ReCalibrate fail.
NO Sensor On Gobo3 Rot	Rotating Gobo3 Indexing sensor not found, Rotating Gobo3 Indexing ReCalibrate fail.
NO Sensor On Prism	Prism sensor not found, Prism ReCalibrate fail.
NO Sensor On Prism_R	Prism Rotate sensor not found, Prism Rotate ReCalibrate fail.
NO Sensor On Prism 2	Prism 2 sensor not found, Prism 2 ReCalibrate fail.
NO Sensor On Prism 2_R	Prism 2 Rotate sensor not found, Prism 2 Rotate ReCalibrate fail.
NO Sensor On Focus	Focus sensor not found, Focus ReCalibrate fail.
NO Sensor On Zoom	Zoom sensor not found, Zoom ReCalibrate fail.
NO Sensor On Frost 1	Frost1 sensor not found, Frost1 ReCalibrate fail.
NO Sensor On Frost 2	Frost2 sensor not found, Frost2 ReCalibrate fail.
NO Sensor On Flow	Flow sensor not found, Flow ReCalibrate fail.
NO Sensor On Intensity	Intensity sensor not found, Intensity ReCalibrate fail.
Ballast_Fault_1	Lamp over voltage(01h)
Ballast_Fault_2	Input voltage too high(02h)
Ballast_Fault_3	Temperature too high(03h)
Ballast_Fault_4	Asymmetry detected(04h)
Ballast_Fault_5	Lamp under voltage(05h)
Ballast_Fault_6	Input voltage too low(06h)
Ballast_Fault_8	NTC defective(08h)
Ballast_Fault_Other	Ballast other fault(0Ah)
Ballast Over Temp	Temperature too high(03h)(same Ballast_Fault_3)
Fan Fault	Fan Fault
Accelerometer Err	Accelerometer Err
Shift Fan Fault	Shift Fan Fault

Routine Maintenance

Lamp Replacement



WARNING: Ensure that power is removed from luminaire when installing lamp.



WARNING: The light source contained in this luminaire shall only be replaced by the manufacturer or his service agent or a similar qualified person.



CAUTION: Wear cotton gloves or other covering while installing lamp. Touching lamp glass with bare fingers will leave oil and may cause the lamp to explode or reduce lamp life. If touched, use alcohol and cotton cloth to thoroughly clean glass portion of lamp.

To replace lamp:

Step1: Ensure power is removed from luminaire.

Step2: Loosen the screws at A, B & C, and remove the metal panel.

Step3: Gently remove the two mains connected to the lamp.

Step4: Remove the latch by loosening the screw, and swing the lamp retaining clip out.

Step5: Hold the lamp by its ceramic base and remove it carefully.

Step6: Check and clean for debris.

Step7: Hold the new lamp by its ceramic base and install it carefully.

Step8: Slide in the lamp retaining clip, place the latch back and tighten the screw.

Step9: Connect the two mains to the lamp.

Step10: Reinstall the metal panel and fasten the screws at A, B & C.

Step11: Apply power to the fixture.

Step12: Reset lamp hours in the menu.

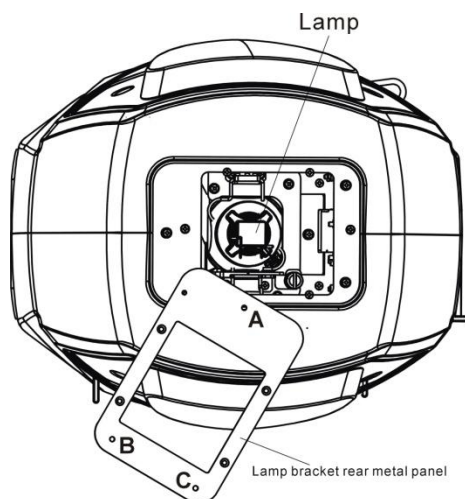

Allow lamp to cool
CAUTION: before servicing.

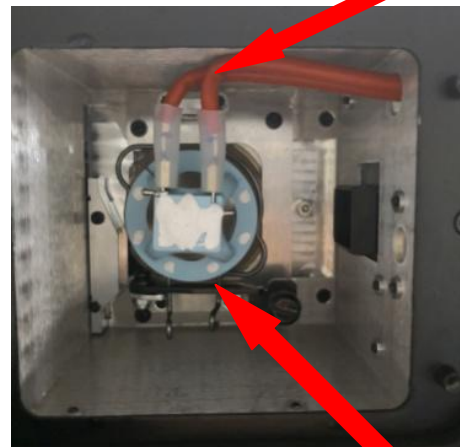

Mains

latch



Do not touch lamp or
CAUTION: reflector with bare fingers.

Figure A-1: Installing Lamp

Gobo Replacement - Gobo Wheels

Tools:

Philips screwdriver

Overview of Gobos used in VL10 BeamWash

Due to the immense energy and light produced by VL10 BeamWash, Vari-Lite recommends to users and owners of this fixture follow the guidelines outlined below when loading gobos in any of the two rotating gobo wheels.

Gobo Use and Positioning

Vari-Lite has purposely selected a set of standard gobos for this fixture and positioned them within the fixture to offer optimum versatility / performance. The gobos supplied - in the standard factory configuration - have been tested in their respective original positions to protect their service life.

Note: For standard factory gobo / gag loads and position, please refer to “[VL10 BeamWash Gobo/ Effects Control](#)” on page 33 of this manual.



Note: Vari-Lite cannot guarantee the service life of any custom gobos or gags when used in conjunction with this fixture. Owners and users employing custom gobos and gags do so at their own risk.

To Install or Replace Gobos



WARNING: Remove power from luminaire before performing maintenance. Gobos may be HOT after operation. Allow to cool before replacing.

To replace a rotating gobo:

Step 1: Remove power from luminaire.

Step 2: As illustrated in Figure A-2, remove top and bottom head cover by loosening four Quick Lock screws to access the gobos wheels.

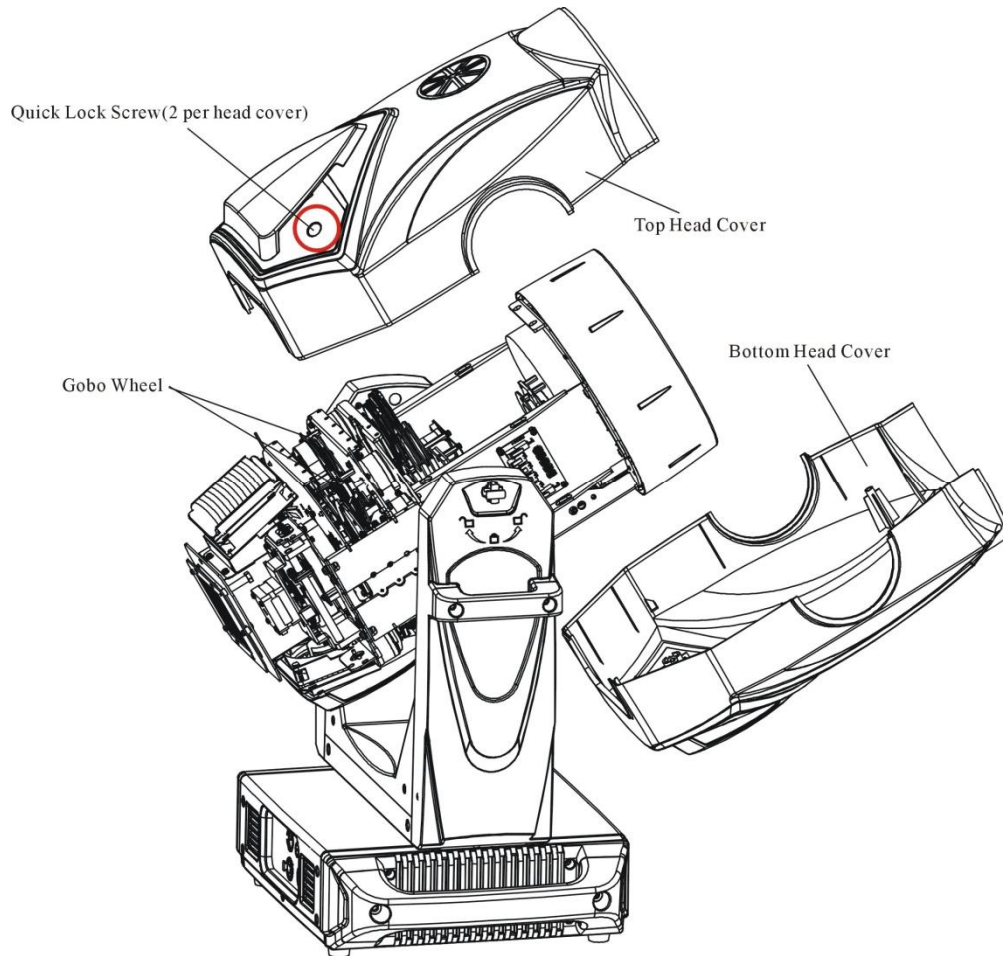

Figure A-2: Head Covers – Removal

Step 3. If removing gobos via bottom of head assembly, undo fan tray assembly with thumb screw to access.

Step 4. Rotate desired gobo wheel until required gobo position is accessible.



CAUTION: Do not push on gobo glass. Press on gobo carrier only.



CAUTION: Do not touch gobos with bare fingers. Wear cotton gloves or other covering while replacing. To clean, refer to [“Cleaning Optics, Filters and Gobos” on page 66.](#)

Step 5. Remove current gobo by carefully pressing on edges of gobo carrier with fingers, pressing gobo toward front end of luminaire (toward lens), and out of wheel.

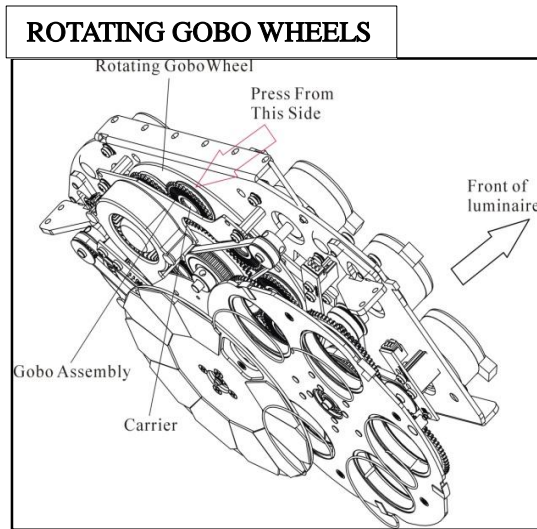

 Do not touch glass with bare fingers.
CAUTION: Press on gobo carrier only.



Figure A-3: Replacing Gobos

Step 6. Install new gobo as follows: (Rotating Gobo Wheel are metal gobos, VLFX Wheel are glass gobos)

- a. Place the gobo holder on a clean, flat work surface with the teeth facing upwards. The gobo is held in place in the gobo holder by a spring. Taking care to avoid scratching or applying pressure to the gobo, lever the end of the spring out, remove the spring and then lift the gobo out of the gobo holder.
- b. See illustration below. Hold the gobo with the dark side facing upwards towards the teeth in the gobo holder. Match up the alignment marks (arrowed) in the gobo and gobo holder. Lay the new gobo flat in the gobo holder.



Figure A-4: Install New Gobo

- c. Insert gobo holder into the Rotating Gobo wheel, ensuring that holder snaps into place.

Step 7. Rotate desired gobo wheel until required gobo position is accessible.

Cleaning Optics, Filters and Gobos



WARNING: Remove power from luminaire before performing maintenance.



WARNING: Acetone is a harsh cleaning agent and solvent. Acetone is very flammable. Please handle acetone according to manufacturer's safety instructions and precautions.

The front lens, optics/color filters, and reflector may require cleaning after extended use.

- **FRONT LENS:** Use a isopropyl alcohol with a soft, lint-free cloth to clean the front lens.
- **OPTICS/COLOR FILTERS/ GOBOS:** Use Acetone or Isopropyl Alcohol along with a soft, lint-free cloth to clean the optics/color filters.
- **REFLECTOR:** Use Acetone or Isopropyl Alcohol along with a soft, lint-free cloth to clean the reflector.



CAUTION: Do not continuously rub color filters or reflector - it may damage or remove the optical coating.

APPENDIX B

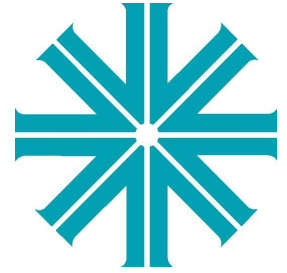

Technical Specifications



VL10 BeamWash

PROGRAMMABLE FUNCTIONS

Color System

Ten color control wheels total. A three filter CMY cross fading system.

Zoom Optics

Covering a range from 2.3° to 44°.

Strobe

High-performance dual blade strobe system capable of ultra-fast operation.

Rotating Gobo Wheels

Two gobo/effects wheels combine to each offer seven rotatable, indexable gobo positions and one open position.

Fixed Gobo Wheel

One fixed gobo wheel combine to each offer dozen unrotatable, indexable gobo positions and one open position.

Edge and Pattern Focus

Variable beam focus to soften edges of gobos. Remarkable depth of field capability allows morphing effects between all pattern and effects wheels.

Variable Frost

Independent, drop-in armature that holds variable frost glass in Wash Mode.

Rotating Prism

Independent, drop-in armature which rotates and holds 4-facet prism and 8-facet prism.

Pan and Tilt

Movement and Speed.

Pan and Tilt Range

Pan - 540°, Tilt - 270°





OPTICAL

Source

Color Temperature

7800K

Output

Beam Mode:27816 lumens

Heavy wash Mode:25283lumens



OPERATIONAL

Power Requirements

Standard AC power distribution from 100-240 VAC, 50/60 Hz.

90 V, 60 Hz.....	752.4 W, 8.389 A, PF 1.000
100 V, 60 Hz.....	741.2 W, 7.422 A, PF 0.997
120 V, 60 Hz.....	726.9 W, 6.084 A, PF 0.994
230 V, 50 Hz.....	703.7 W, 3.165 A, PF 0.967
264 V, 50 Hz.....	701.5 W, 2.798 A, PF 0.949

Control

Compatible with a wide variety of DMX512 consoles.

DMX Channels

41

Mounting Position:

The VL10 BeamWash can be mounted and operated in any orientation.

Weight

33.01kg (73.7 lbs)

Dimensions

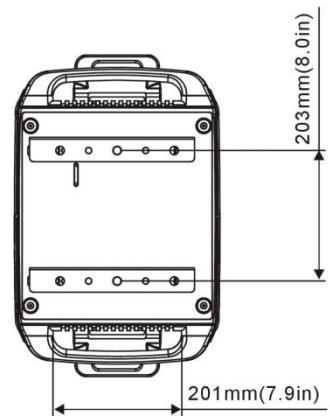
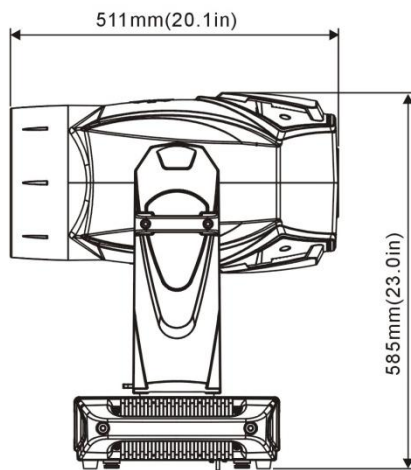
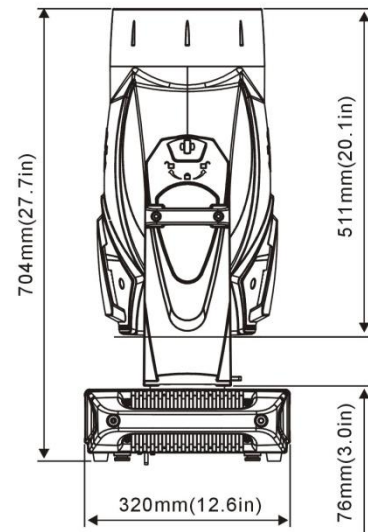
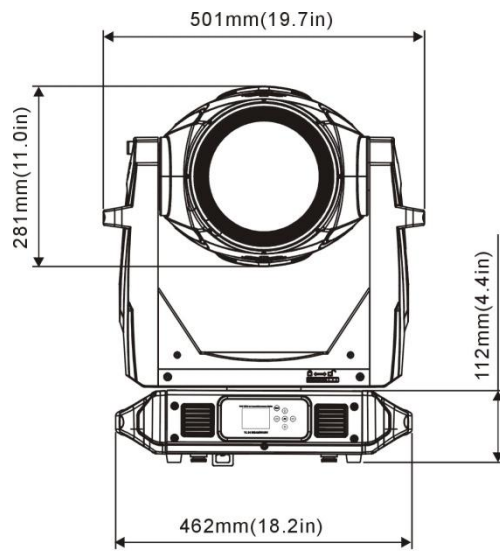

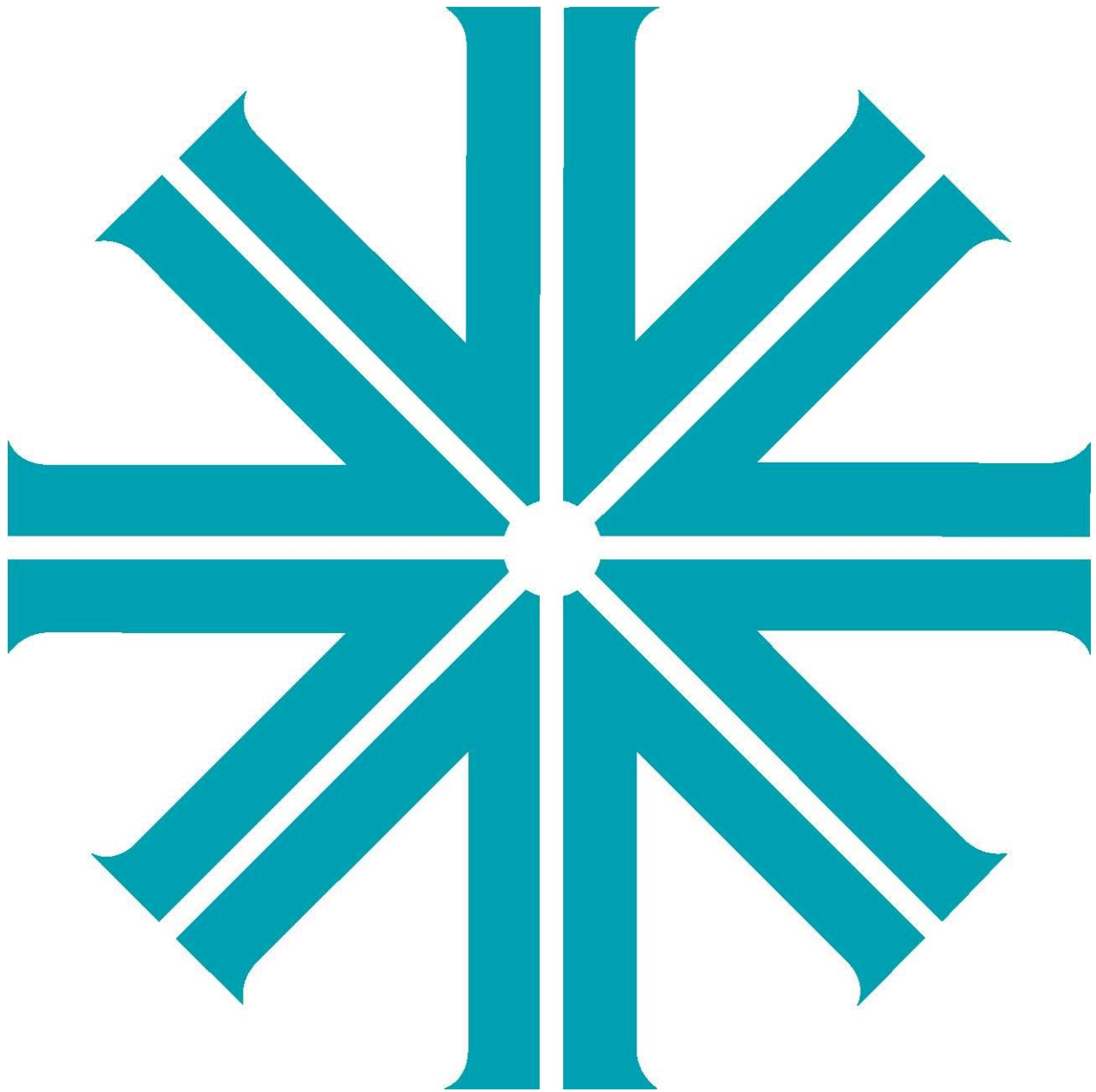

Vari-Lite
10911 Petal Street
Dallas, Texas 75238 USA
1-877-VARI-LITE . 1-214-647-7880
<http://www.philips.com/entertainmentlighting>
©2013 Vari-Lite company. All Rights Reserved.